

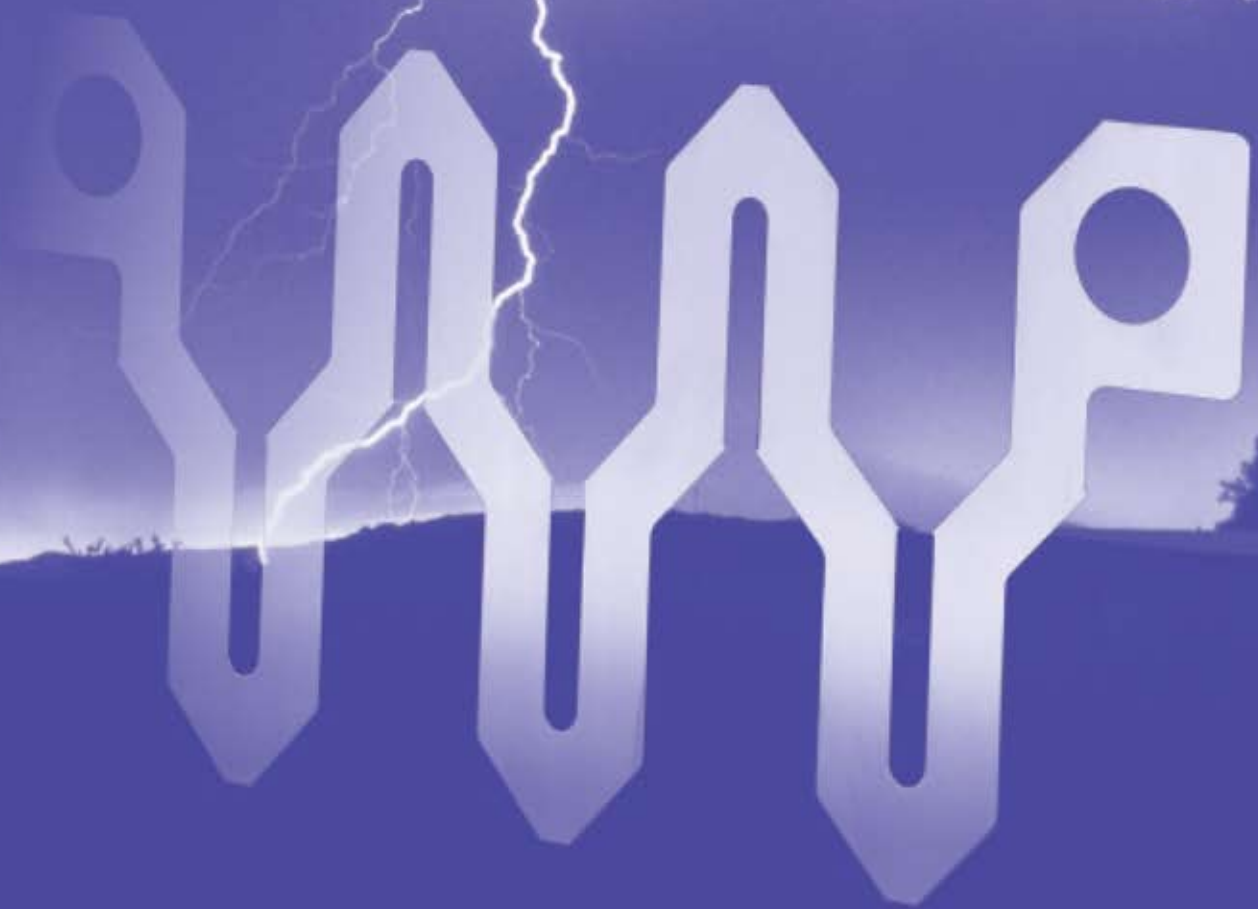

Post Glover
Motor Control, Crane Control,
Dynamic Braking, and
Ballast Resistors
Technical Bulletin



Post GloverTM

"The Resistor Specialists"



POST GLOVER RESISTORS INC.

Post Glover
Motor Control, Crane Control, Dynamic
Braking, and Ballast Resistors



– Table of Contents –

Introduction	2
Motor Control	
AC Wound Rotor Induction Motor (Slip Ring Motor)	3
DC Series Wound Motor	3
AC Squirrel Cage Induction Motor	4
Wye-Delta Closed-Transition Starting	4
Crane Control	5–6
Dynamic Braking	
Dynamic Braking Technology	7
Dynamic Braking Resistor Designs	8
Information Required for Sizing	8
3-Leg Adjustable Ballast Resistors	9
NEMA Tables	10–11

Post Glover[™]

“The Resistor Specialists”



Introduction

Post Glover specializes in motor control resistors—the most popular use of our resistors—for severe duty applications. Our resistors make it possible to start and stop extremely powerful electric motors—such as those on cranes, compressors, and pumps—with safety and precision.

The resistor functions to control the torque and/or speed of an electrical motor or limit the initial current inrush to an acceptable level. This is accomplished through the use of manual or magnetic controls, or with solid-state controls.

In harsh environments, such as foundries and steel mills, motors and resistors must be able to withstand “plugging”—a type of motor braking provided by reversing the voltage polarity or phase sequence so that the motor develops a counter-torque and brakes the load.

They must also withstand dynamic braking, fast acceleration of heavy loads, large amounts of dust and dirt, and occasional operator abuse. In these instances, Post Glover's stainless steel stamped grid resistors offer excellent service and cost efficiency.

The most popular uses of Post Glover resistors are control of AC wound rotor induction motors (slip ring motors), DC series wound motors, and AC squirrel cage induction motors. Our resistors are also commonly used for wye-delta closed-transition starting applications.

Motor Control

AC Wound Rotor Induction Motor (Slip Ring Motor)

The resistor is wired into the motor secondary slip rings, where it dissipates torque energy in the form of heat. It also provides "soft starting" as resistance is removed in steps.

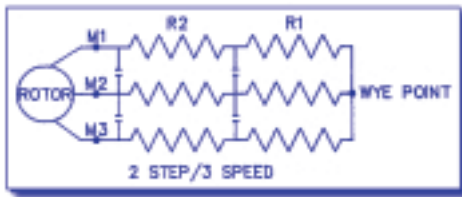

Initial information needed for sizing your resistor:

- ⌘ Application
- ⌘ Horsepower
- ⌘ Secondary volts
- ⌘ Secondary amps
- ⌘ Starting torque
- ⌘ Number of speeds
- ⌘ Duty/NEMA class (see tables)



DC Series Wound Motor

The resistor limits torque by limiting current flow to the motor. It is used for starting and stopping the motor.

Initial information needed for sizing your resistor:

- ⌘ Application
- ⌘ Horsepower
- ⌘ Line voltage
- ⌘ Full load amps
- ⌘ Starting torque
- ⌘ Number of speeds
- ⌘ Duty/NEMA class (see tables)
- ⌘ For dynamic lowering applications, include manufacturer of control

Wye-Delta Closed Transition Starting Resistors

* All units are provided with a mill galvanized louvered cover.

AC Squirrel Cage Induction Motor

Commonly known as a "reduced-voltage" or "ballast" resistor, this resistor acts as a voltage divider for soft starting of the motor.

Initial information needed for sizing your resistor:

- ⌘ Application
- ⌘ Horsepower
- ⌘ Line voltage
- ⌘ Full load amps
- ⌘ Duty cycle/NEMA class (see tables)

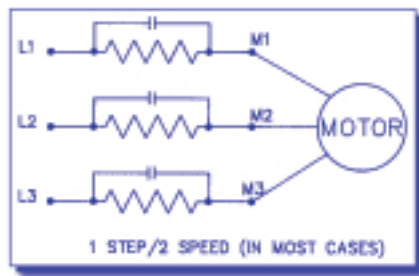

Wye-Delta Closed-Transition Starting

Wye-delta is a reduced-inrush starting method in which 3-phase motor stator coils are initially connected in a wye configuration and switched to delta as the motor's speed increases. The resistor works as a reduced-voltage starting resistor by starting a motor at 58% reduced voltage.

Initial information needed for sizing your resistor:

- ⌘ Application
- ⌘ Horsepower
- ⌘ Line voltage
- ⌘ Full load amps
- ⌘ Duty/NEMA class (see tables)

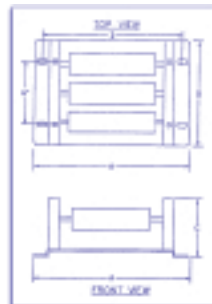

For other applications, such as small horsepower motors, dynamic braking, and field discharge, please give us a call. We offer free engineering assistance to our customers for all motor control applications.

230 VOLTS AC*

HP	FLA	DIMENSIONS				POST GLOVER P/N
		A	B	C	D	
1	4.2	15"	10"	6"	13.5"	YD- 10 -230
1.5	6	15"	10"	6"	13.5"	YD- 15 -230
2	6.8	15"	10"	6"	13.5"	YD- 20 -230
3	9.6	15"	10"	6"	13.5"	YD- 30 -230
5	15.2	15"	10"	6"	13.5"	YD- 50 -230
7.5	22	15"	10"	6"	13.5"	YD- 75 -230
10	28	15"	10"	6"	13.5"	YD- 100 -230
15	42	15"	10"	6"	13.5"	YD- 150 -230
20	54	15"	10"	6"	13.5"	YD- 200 -230
25	68	15"	10"	6"	13.5"	YD- 250 -230
30	80	15"	10"	6"	13.5"	YD- 300 -230
40	104	15"	10"	6"	13.5"	YD- 400 -230
50	130	15"	10"	6"	13.5"	YD- 500 -230
60	154	15"	10"	6"	13.5"	YD- 600 -230
75	192	15"	10"	6"	13.5"	YD- 750 -230
100	248	15"	10"	6"	13.5"	YD-1000 -230
125	312	15"	10"	6"	13.5"	YD-1250 -230
150	360	15"	10"	6"	13.5"	YD-1500 -230
200	480	22"	10"	6"	20.5"	YD-2000 -230
250	600	22"	10"	6"	20.5"	YD-2500 -230
300	720	22"	10"	6"	20.5"	YD-3000 -230
350	840	29.5"	10"	6"	28.0"	YD-3500 -230
400	960	22"	10"	11"	20.5"	YD-4000 -230
450	1080	22"	10"	11"	20.5"	YD-4500 -230
500	1200	22"	10"	11"	20.5"	YD-5000 -230

460 VOLTS AC*

HP	FLA	DIMENSIONS				POST GLOVER P/N
		A	B	C	D	
1	2.1	15"	10"	6"	13.5"	YD- 10 460
1.5	3	15"	10"	6"	13.5"	YD- 15 460
2	3.4	15"	10"	6"	13.5"	YD- 20 460
3	4.8	15"	10"	6"	13.5"	YD- 30 460
5	7.6	15"	10"	6"	13.5"	YD- 50 460
7.5	11	15"	10"	6"	13.5"	YD- 75 460
10	14	15"	10"	6"	13.5"	YD- 100 460
15	21	15"	10"	6"	13.5"	YD- 150 460
20	27	15"	10"	6"	13.5"	YD- 200 460
25	34	15"	10"	6"	13.5"	YD- 250 460
30	40	15"	10"	6"	13.5"	YD- 300 460
40	52	15"	10"	6"	13.5"	YD- 400 460
50	65	15"	10"	6"	13.5"	YD- 500 460
60	77	15"	10"	6"	13.5"	YD- 600 460
75	96	15"	10"	6"	13.5"	YD- 750 460
100	124	15"	10"	6"	13.5"	YD-1000 460
125	156	15"	10"	6"	13.5"	YD-1250 460
150	180	15"	10"	6"	13.5"	YD-1500 460
200	240	22"	10"	6"	20.5"	YD-2000 460
250	300	22"	10"	6"	20.5"	YD-2500 460
300	360	22"	10"	6"	20.5"	YD-3000 460
350	420	29.5"	10"	6"	28"	YD-3500 460
400	480	29.5"	10"	6"	28"	YD-4000 460
450	540	29.5"	10"	6"	28"	YD-4500 460
500	600	29.5"	10"	6"	28"	YD-5000 460

575 VOLTS AC*

HP	FLA	DIMENSIONS				POST GLOVER P/N
		A	B	C	D	
3	3.9	15"	10"	6"	13.5"	YD- 30 575
5	6.1	15"	10"	6"	13.5"	YD- 50 575
7.5	9	15"	10"	6"	13.5"	YD- 75 575
10	11	15"	10"	6"	13.5"	YD-100 575
15	17	15"	10"	6"	13.5"	YD-150 575
20	22	15"	10"	6"	13.5"	YD-200 575
25	27	15"	10"	6"	13.5"	YD-250 575
30	32	15"	10"	6"	13.5"	YD-300 575
40	41	15"	10"	6"	13.5"	YD-400 575
50	52	15"	10"	6"	13.5"	YD-500 575
60	62	15"	10"	6"	13.5"	YD-600 575
75	77	15"	10"	6"	13.5"	YD-750 575
100	99	15"	10"	6"	13.5"	YD-1000 575
125	125	15"	10"	6"	13.5"	YD-1250 575
150	144	15"	10"	6"	13.5"	YD-1500 575
200	192	22"	10"	6"	20.5"	YD-2000 575
250	240	22"	10"	6"	20.5"	YD-2500 575
300	288	29.5"	10"	6"	28"	YD-3000 575
350	336	29.5"	10"	6"	28"	YD-3500 575
400	384	29.5"	10"	6"	28"	YD-4000 575
450	432	29.5"	10"	6"	28"	YD-4500 575
500	480	29.5"	10"	6"	28"	YD-5000 575

Crane Control

When overhead cranes are used in industrial facilities, resistor banks are frequently used for control of hoisting and lowering speeds, as well as positioning the crane itself. Resistors are usually mounted in, or on top of, the bridge structure.

Many steel mills use DC motors because, in the past, DC power was the best way to hoist heavy loads. Newer plants are increasingly utilizing more readily available three-phase power, and wound rotor motors are often employed.

In hoisting and lowering operations, some special considerations are involved. Hoisting is straightforward—the load is resisting the motor, and positive torque against gravity is required. In lowering an empty hook, it may be necessary to drive the hook down, since gravity may be insufficient to lower it at the desired speed.

But, when the hook is loaded, the load may tend to overhaul the motor, which then may have to apply a retarding torque as if it were hoisting. Dynamic braking ensures the load won't run away and crash instead of making a soft landing.



All of these conditions require modifications of the speed-torque curve of the hoist motor. This is readily achieved by applying the proper amount of external armature and field resistance.

A resistor bank is the practical device available for the purpose. Operators effect changes in motor speed with various loads and operate a bank of magnetic contactors to achieve the desired operation. The contactors change taps on the resistor banks as required to maintain appropriate rotor circuit resistance.

Post Glover's stainless steel grid resistors are an excellent choice for heavy industrial applications because of their durability and dependability in severe environments.

Initial information needed for sizing your resistor:

- ⌘ Application
- ⌘ Horsepower
- ⌘ Line voltage
- ⌘ Full load amps
- ⌘ Starting torque
- ⌘ Number of speeds
- ⌘ Duty/NEMA class (see tables)
- ⌘ For dynamic lowering applications, include manufacturer of control package.

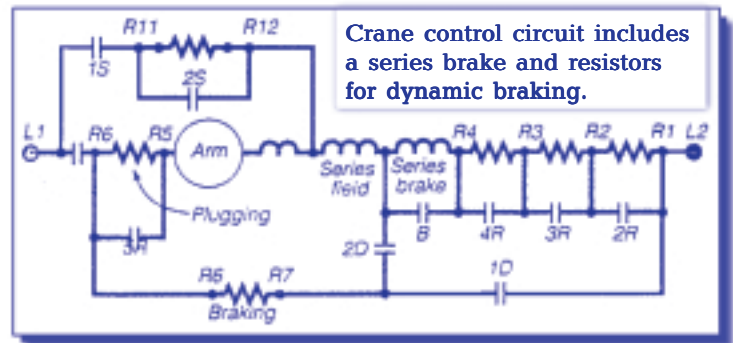

Dynamic Braking

Dynamic braking resistors are used on AC variable frequency drives (VFDs) to dissipate energy that is produced in the motor as the drive provides braking torque to stop the motor. The resistors are either used alone for decelerating or in conjunction with compressed-air brakes for stopping. The excitation voltage of the traction motors generally comes from a static converter powered by the overhead catenary and operates as a DC voltage transformer.

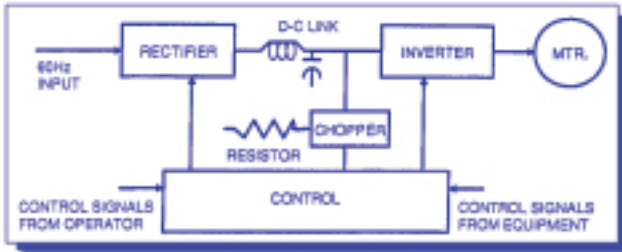
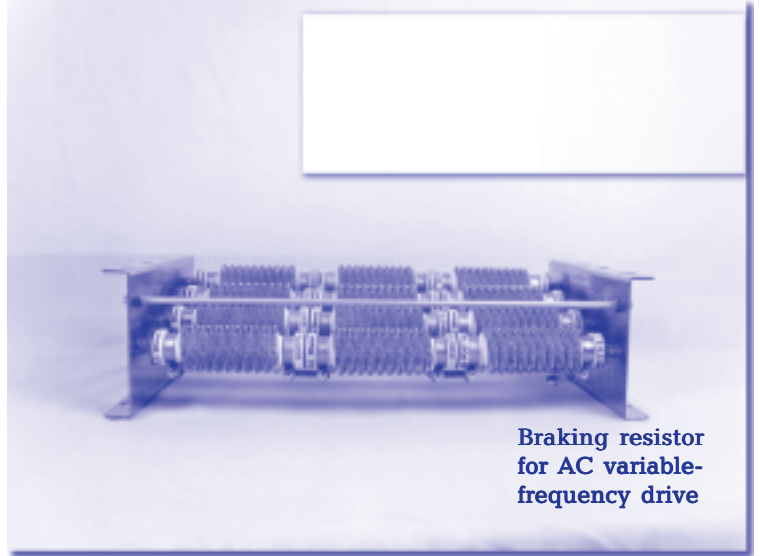

Dynamic Braking Technology

Resistors integrated into the power unit dissipate electrical energy created by electric braking systems. The dynamic braking resistor is connected to the DC bus and will see voltages as high as 800 volts during braking conditions.

The drive manufacturer normally determines the power rating (watts) needed to prevent overheating during braking duty. The peak braking current is determined by the specified resistance value. Each drive manufacturer specifies a resistance range with a minimum to prevent overcurrent and damage to the drive and a maximum value to give adequate lower dissipation capability.

A three-phase variable frequency drive (VFD) consists of three basic components—rectifier, DC line, and inverter—and a control system to manage these three components as illustrated above. The rectifier converts the three-phase 60Hz AC input to a DC signal.

Depending on the system, an inductor, a capacitor, or combination of these components smooths the DC signal (reduces voltage ripple) in the DC link part of the VFD. The inverter circuit converts the DC signal into a variable frequency AC voltage to control the speed of the induction motor.

During braking, the VFD ramps the frequency to zero. The rotational energy of the motor and load are driven back through the inverter to the DC bus and the rotational energy is dissipated through the resistor.

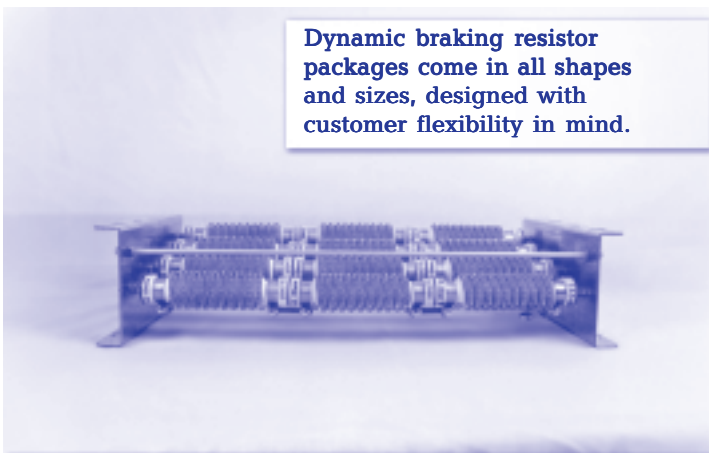

Dynamic Braking Resistor Designs

Our LC wirewound resistors are used for most dynamic braking applications. These are conveniently provided on L-shaped mounting brackets or in standard enclosures with louvered or screened covers. For slightly higher wattage applications, our EW-style edgewound resistor is proven highly efficient.

For heavy duty applications that require even higher wattage, we recommend Post Glover stainless steel stamped grid resistor elements. The stamped grid design was developed and patented by Post Glover over 60 years ago and is used around the world for severe-duty applications.

Information Required for Sizing

Three factors must be known for sizing your resistor:

1. Ohms
2. Watts
3. Braking cycle (time on/time off)
4. Drive manufacturer

Ohms are determined by the drive manufacturer and are usually stated as a range or a minimum value.

Watts are stated as either a maximum braking power or continuous braking power. In either case, the wattage rating of the resistor is calculated by the braking cycle.

Braking cycle is usually stated as a percentage; however, the actual times on and off are required to offer the optional resistor package while minimizing the size and cost.

Example

An application requires a braking resistor rated 25 ohms with an average power during braking of 2500 watts. The duty cycle is 20%—10 seconds on and 40 seconds off—with a cycle time of 50 seconds.

The ohmic value of the resistor is typically between -0% and +5%—therefore, 25.0–26.25 ohms.

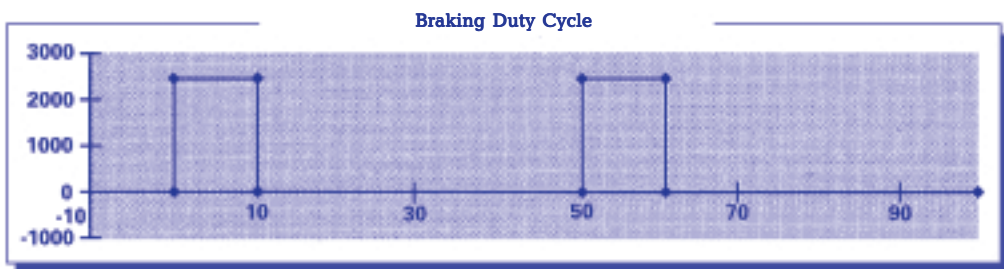

3-Leg Adjustable Ballast Resistors

3-Leg adjustable ballast resistors are used with small horsepower, typically 1/4 to 5 HP, squirrel-cage induction motors for soft starting, reduced speed or two speed control of small cranes. Additional ratings up to 10 horsepower are available.

These resistors are factory set for 70% reduced voltage (50% of normal starting torque) and are available for 230, 460 and 575 volts AC.

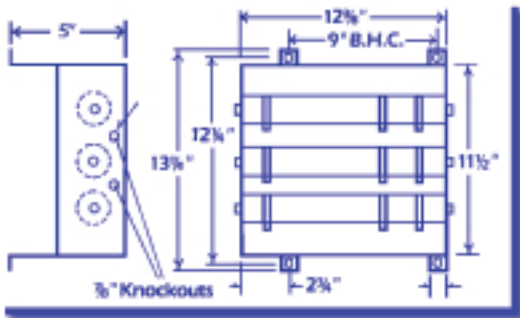
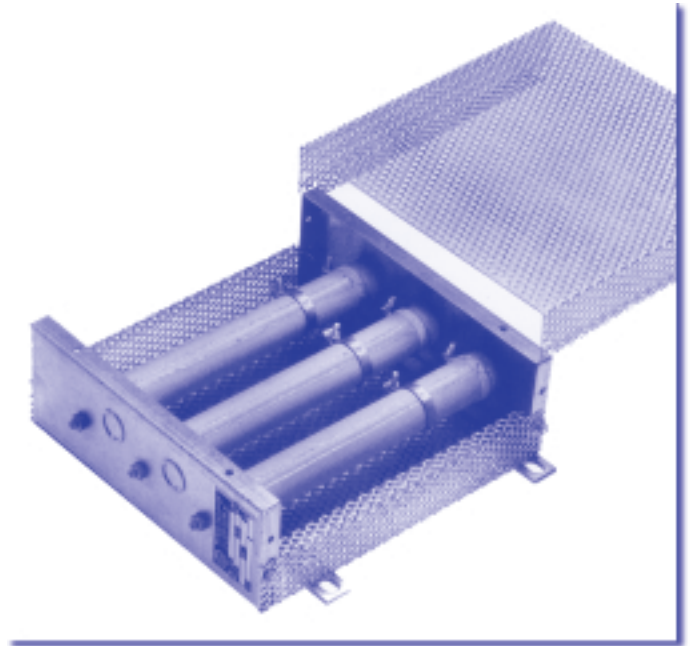

Construction

These units consist of three smoothwound adjustable resistors in a ventilated, wall-mount enclosure. Knockouts are provided on both ends for convenient and fast wiring. A removable front cover provides easy access to coils for adjusting the starting torque or speed.

3-LEG ADJUSTABLE BALLAST RESISTORS			
Part Number	Horsepower	Ohms†	Cont. Amps*
230 VAC			
BR-14-230	1/4	46.5	1.4
BR-13-230	1/3	46.5	1.8
BR-12-230	1/2	19.8	2.1
BR-34-230	3/4	15.2	2.8
BR-100-230	1	10.0	3.5
BR-150-230	1 1/2	7.5	4.8
BR-200-230	2	5.5	6.3
BR-300-230	3	3.8	9.0
BR-500-230	5	2.7	14.0
460 VAC			
BR-14-460	1/4	150.0	.7
BR-13-460	1/3	150.0	.9
BR-12-460	1/2	68.0	1.0
BR-34-460	3/4	48.0	1.4
BR-100-460	1	39.0	1.7
BR-150-460	1 1/2	28.0	2.4
BR-200-460	2	19.5	3.2
BR-300-460	3	16.8	4.5
BR-500-460	5	12.4	7.0
575 VAC			
BR-12-575	1/2	106.0	.8
BR-34-575	3/4	75.0	1.1
BR-100-575	1	62.7	1.4
BR-150-575	1 1/2	46.2	1.9
BR-200-575	2	32.5	2.5
BR-300-575	3	23.7	3.5
BR-500-575	5	17.5	5.6

* Continuous Amp capacity at 375° rise.

† Resistance in Ohms at 25°C.

NEMA Classification of Resistors

Table of Classification of Resistors

CLASS NUMBERS APPLYING TO DUTY CYCLES								
Approx. Per Cent of Full Load Current on First Point	30 Sec. on Out of Each 15 Min.	5 Sec. on Out of Each 80 Sec.	10 Sec. on Out of Each 80 Sec.	15 Sec. on Out of Each 90 Sec.	15 Sec. on Out of Each 60 Sec.	15 Sec. on Out of Each 45 Sec.	15 Sec. on Out of Each 30 Sec.	Continuous Duty
25	101	111	131	141	151	161	171	91
50	102	112	132	142	152	162	172	92
70	103	113	133	143	153	163	173	93
100	104	114	134	144	154	164	174	94
150	105	115	135	145	155	165	175	95
200 or over	106	116	136	146	156	166	176	96

When an armature shunt resistor is added, the class number shall include the Suffix-AS. Example: Class 155-AS is a resistor which includes an armature shunt and which will allow an initial inrush of 150 percent with the armature shunt open. When a dynamic braking resistor is added, the class number shall include the suffix-DB.

The following table is intended as a guide in the specifying or designing of resistors. The classifications are those that experience has shown to be correct for the average installation. There will, however, be exceptions. This table is applicable to nonbreakable steel grid resistors, provided that the time-on period does not exceed the values given in the Table of Classification of Resistors.

NEMA Resistor Application Table

Installation	Resistance Class Number	Installation	Resistance Class Number	Installation	Resistance Class Number
BLOWERS		Levelers	153	METAL MINING	
Centrifugal	133-93	Manipulator Fingers	153-163	Ball, Rod and Tube Mills	135
Constant Pressure	135-95	Pickling Machine	153	Car Dumpers-Rotary	153
BRICK PLANTS		Pilars-Slab	153	Converters-Cooper	154
Augers	135	Racks	153	Conveyors	135
Conveyors	135	Reelers	135	Crushers	145
Dry Pans	135	Saws-Hot or Cold	155	Tilting Furnace	153
Pug Mills	135	Screw Downs	153-163	PAPER MILLS	
BY-PRODUCT COKE PLANTS		Shears	155	Beaters	135
Door Machine	153	Shuffle Bars	155	Calenders	154-92
Leveler Ram	153	Side Guards	153-163	PIPEWORKING	
Pusher Bar	153	Sizing Rolls	155	Cutting and Threading	135
Valve Reverting Machine	153	Slab Buggy	155	Expanding and Flanging	135-95
CEMENT MILLS		Soaking Pit Covers	155	POWER PLANTS	
Conveyors	135	Straighteners	153	Clinker Grinders	135
Crushers	145	CRANES		Coal Crushers	135
Elevators	135	Tables-Approach	153	Conveyors-	
Rolary Dryers	145-95	Lift	153-163	Belt	135
Grinders and Pulverizers	135	Roll	153	Screw	135
Kilns	135-95	Shear Approach	153-163	Pulverized Fuel Feeders	135
COAL AND ORE BRIDGES		Transfer	153	Pulverizers-	
Bridge	153	Main Roll	153-163	Ball Type	135
Closing	162	Tilting Furnace	153	Centrifugal	134
Holding	162	Wire Stranding Machine	153	Stokers	135-93
Trolley	163	CRANES-GENERAL PURPOSE		PUMPS	
COAL MINES		Hoist	153	Centrifugal	134-93
Car Hauls	162	Bridge or Trolley with		Plunger	135-95
Conveyors	135-55	Roller Bearings	152	RUBBER MILLS	
Cutters	135	Sleeve Bearings	153	Calenders	155
Crushers	145	FLOUR MILLS		Crackers	135
Fans	134-93	Line Shafting	135	Mixing Mills	135
Hoists-		FOOD PLANTS		Washers	135
Slope	172	Butter Churns	135	STEEL MILLS	
Vertical	162	Dough Mixers	135	Accumulators	153
Jigs	135	HOISTS		Casting Machines-Pig	153
Picking Tables	135	Winch	153	Charging Machines-	
Rotary Car Dumpers	153	Mine Slope	172	Bridge	153-163
Shaker Screens	135	Mine Vertical	162	Peel	153-163
COMPRESSORS		Contractor's Hoists	152	Trolley	153-163
Constant Speed	135	LARRY CARS	153	Coiling Machines	135
Varying Speed-		LIFT BRIDGES	152	Converters Metal	154
Centrifugal	93	MACHINE TOOLS		Conveyors	135-155
Plunger Type	95	Bending Rolls	163-164	WOODWORKING PLANTS	
CONCRETE MIXERS	135	Boring Mills	135	Boring Machine	115
CRANES		Bulldozers	135	Lathe	115
Hoist	153-163	Drills	115	Mortiser	115
Bridge or Trolley with		Gear Cutters	115	Moulder	115
Roller Bearings	152-162	Grinders	135	Planers	115
Sleeve Bearings	153-163	Hobbing Machines	115	Power Trimmer and Mitre	115
Crushers	145	Lathes	115	Sanders	115
Furnace Doors	155	Milling Machines	115	Saws	115
Gas Valves	155	Presses	135	Shapers	115
Gas Washers	155	Punches	135	Shingle Machine	115
Hot Metal Mixers	163	Saws	115		
Ingot Buggy	153	Shapers	115		
Kickoff	153				



Post Glover makes hundreds of designs of motor control, crane control, dynamic braking, and ballast resistors. For the best value and maximum performance from your resistors, consult with one of our resistor engineering design consultants about your application. Knowledgeable solutions have made Post Glover a leader in heavy-duty resistors, worldwide.

Post Glover: Heavy-Duty Resistors for Tough Applications

- /// Neutral Grounding Resistors
- /// High Resistance Grounding Systems
- /// Harmonic Filtering
- /// Load Banks
- /// Motor and Crane Control
- /// Dynamic Braking
- /// Transit and Locomotive
- /// Off-Highway Trucks
- /// Enclosures
- /// Ballast Resistors
- /// Heaters
- /// Custom Resistor Designs

For pricing information, please contact us at 1-800-537-6144 (U.S.A. only)

Phone: (859) 283-0778

Fax: (859) 283-2978

Post Glover[™]
"The Resistor Specialists"



For more information
about Post Glover Resistors
or to place an order,
call 1-800-537-6144

Headquarter Offices:

POST GLOVER RESISTORS
P.O. Box 18666
1369 Cox Avenue
Erlanger, KY 41018 USA

Telephone: (800) 537-6144 or (859) 283-0778
Fax: (859) 283-2978
E-mail: sales@postglover.com
Internet: <http://www.postglover.com>

POST GLOVER SDN. BHD.
Head Office: HALMA ASIA PTE. LTD
54 Genting Lane
#05-02 Hiang Kie Complex 2
Singapore 349562

Telephone: 65-7452936
Fax: 65-7450467
E-mail: postglover@po.jaring.my
halma@singet.com.sg

Post GloverTM

"The Resistor Specialists"