

PulserPlus.Net™ Low Voltage High Resistance Grounding System

Installation, Operation and Maintenance Instructions

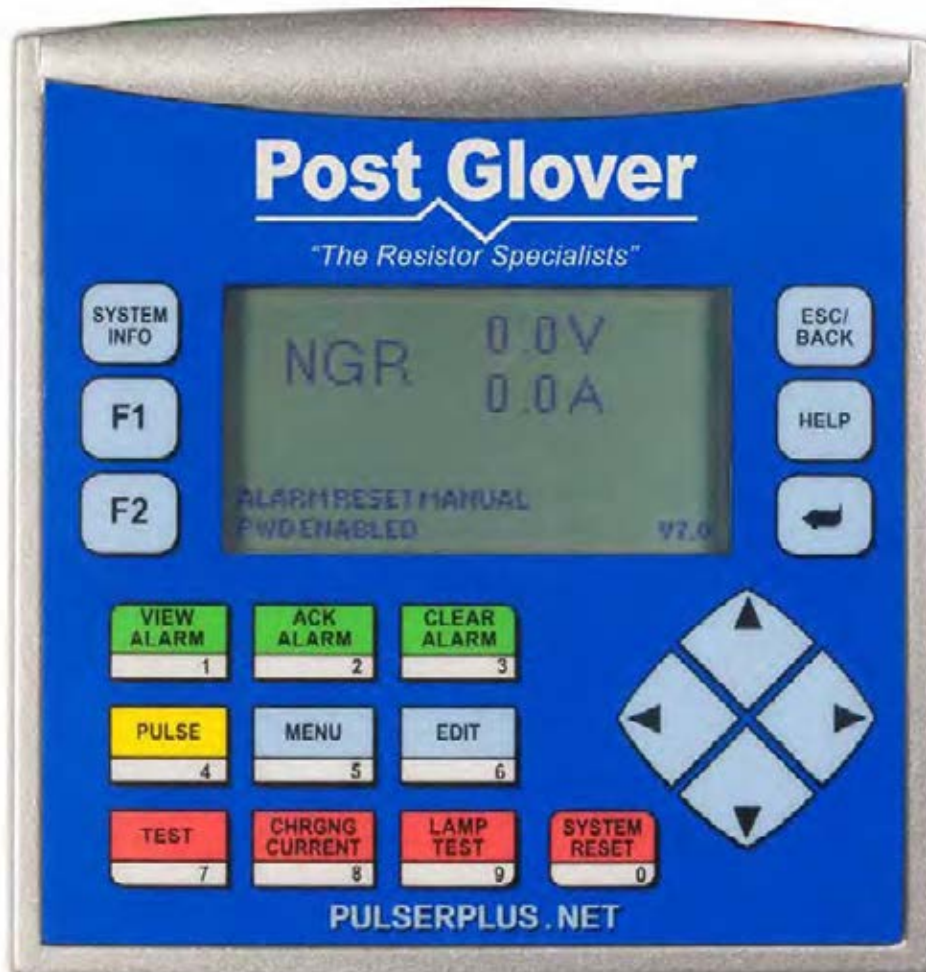

Software Version 7



PULSERPLUS.NET™ INSTRUCTION MANUAL

Revision	Date	Changes
HR105-10		Original Release
HR105-11	6/30/2011	9.5: Added Troubleshooting section 11.2: Corrected Com Port setting procedure Added Control Screen Navigation flowchart Added new control screens 11.3: Rewording of alarm/event screen descriptions Added new event screens 11.4: Corrected the procedure and Added parameter range table 11.5: Removed detail from Data Table section 11.7: Removed detail from communication section 11.9: Added procedure to change time and date Appendix A: Changed Schematic Section Appendix D: Removed "Data Table Access via Modbus" Added Customer Connection Details
HR105-12	9/4/2012	5: Inserted note about password protection 5.4: Clarified V_{test} 11.1: Changed Pulse button description in the table 11.1.1: Added procedure for disabling/re-enabling password protection 11.2.2: Added title: Control and Data Entry Screen Descriptions 11.2.2.15: Added controller screen: RS-485 baud rate 11.4: Added descriptive detail to parameters in table 11.8: Modified the procedure to include upgrades
HR105-13	7/31/2013	8.4: Changed Resistor Check Operation Description 8.5: Added Resistor Check Setup Procedure 8.6: Moved table from 8.5 to this section. 11.2.1: Modified Control Screen Flowchart 11.2.2.16: Added Sensing Resistor Parameters Screen A.3. Revised Troubleshooting Schematic
HR105-14	3/1/2014	1: Section re-written. 4.8: Text change 10: Added to step 5. 11.1: Button password requirements corrected 11.2.1: Modified Control Screen Flowchart 11.2.2.13: Changed Ethernet Port Screen 11.2.2.14: Changed Operating Mode Screen 11.2.2.17: Added LVM Control Screen 11.2.2.18: Added UTC and Socket Setting Screen 11.2.2.19: Added Sensing Resistor Mode Screen 11.3.2.15: Added Active Sensing Mode disabled Event screen 11.3.2.16: Added Active Sensing Mode enabled Event screen 11.4: Added parameters to default settings table Appendix E: Added Active Open Circuit Detection.
HR105-15	1/5/2015	1.2: Reference to Appendix D added. 1.5: Reference to section 11.1.1 added. 9. Expanded troubleshooting. 11.1.1: Added Visual Instruction 11.6: Added Visual Instruction 11.8: Added Visual Instruction 11.9: Added Visual Instruction
HR105-18	2/9/2018	Review and edit all sections Update for Software Major Revision V7.0

Table of Contents

Section 1 – Equipment Overview.....	4
Section 2 – Installation	7
Section 3 – Start-up Guide	9
Section 4 – Operational Description	16
Section 5 – Charging Current & Resistor Tap Setting.....	25
Section 6 – Troubleshooting	27
Section 7 – Locating a Ground Fault.....	32
Section 8 – User Interface	33
Section 9 – Maintenance.....	42
Appendix A – Schematics	43
Appendix B – Dimension Drawings.....	46
Appendix C – Control Specifications	48
Appendix D – Customer Connection Details.....	50
Appendix E – Setup Report Form	51

Please note that throughout this digital document, there is blue hyper-linked text that will take you to the referenced page.

Section 1 – Equipment Overview



1.1. Front View

- Lifting angles
- Audible alarm
- Indicating lights (System Normal, Ground Fault, Pulsing)
- Disconnect switch (disconnects power and system neutral)
- Instruction overview
- User interface
- Resistor vents

Acronyms

Acronyms	
NGR	Neutral Grounding Resistor
HRG	High Resistance Grounding
PLC	Programmable Logic Controller
PEM	Pulser Electronics Module
LVM	Line Voltage Monitoring
PP.Net	PulserPlus.net

PULSERPLUS.NET™ INSTRUCTION MANUAL

1.2 Interior View - Controls

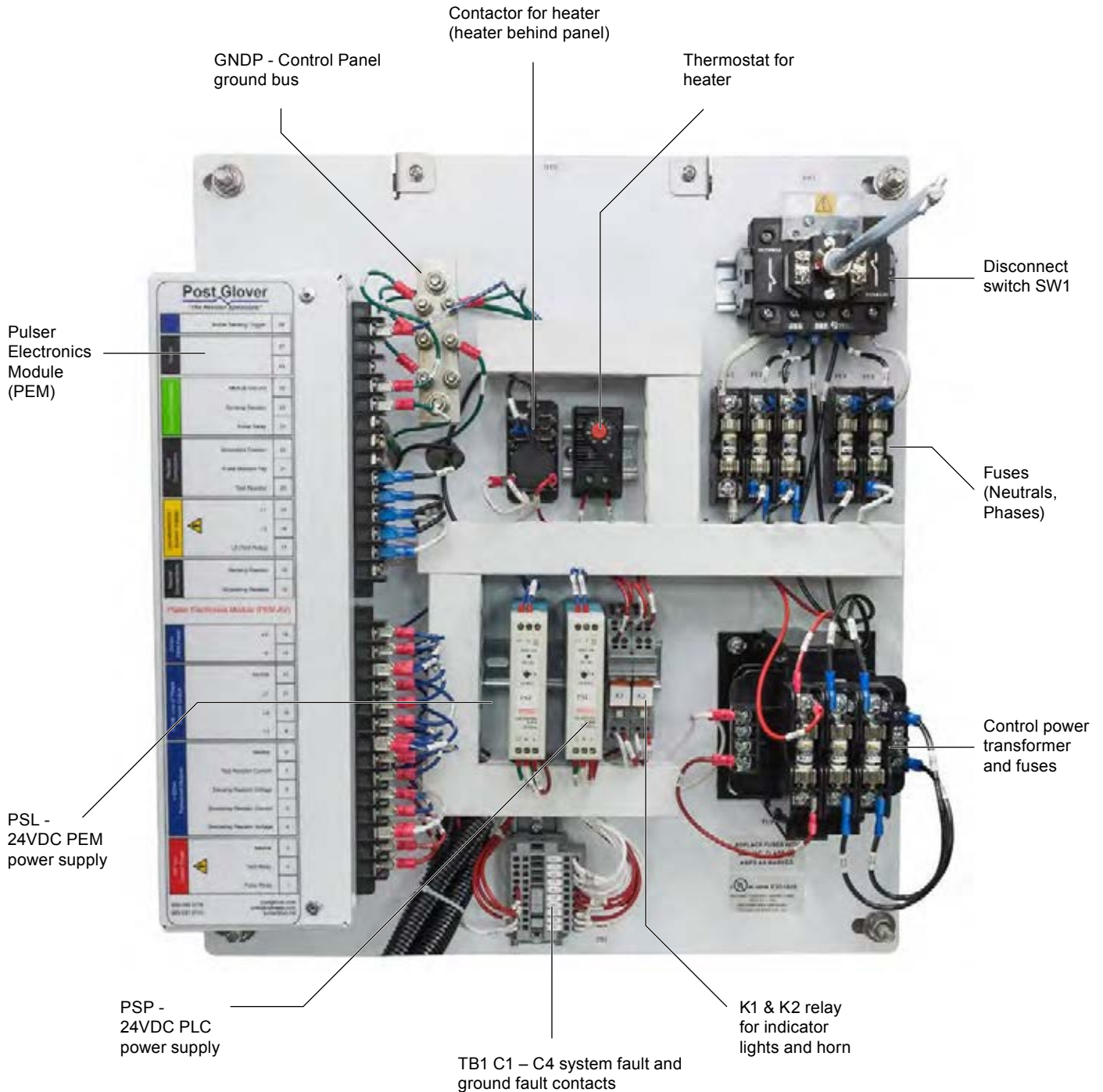

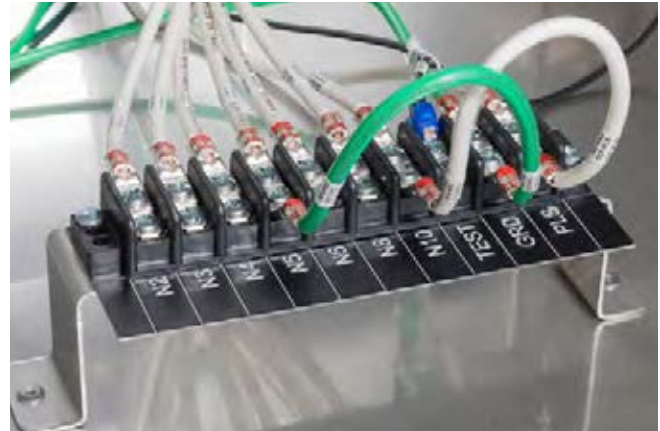
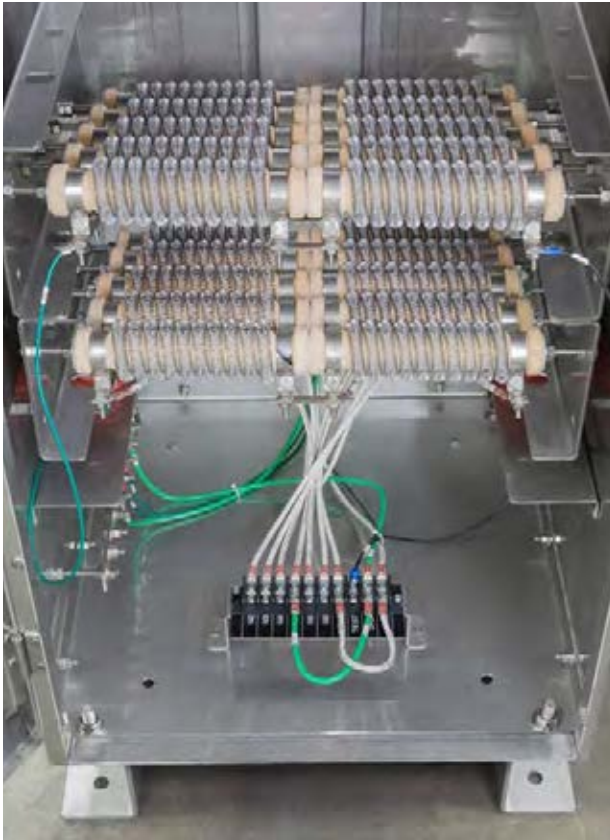

1.3 Interior View - Resistors

- Neutral grounding resistors (NGR)
- Terminal strip for tap adjustment (Factory set for 5 amps with 10 amp pulse)

1.4 PLC Operator Interface

- Blue buttons are for navigation
- Green buttons are for alarm management
- The Yellow button is for troubleshooting
- Red buttons are for System testing and reset
- Numbered buttons are for parameter value entry and for menu selections.

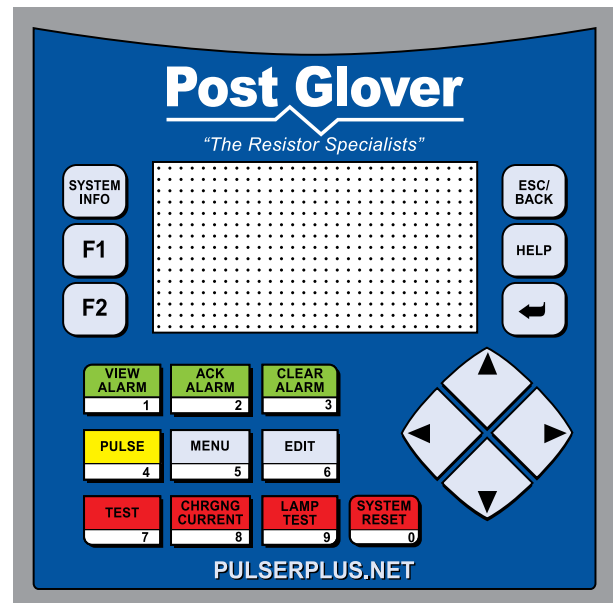

Section 2 – Installation

This instruction booklet is intended as a general guidance tool for personnel installing Post Glover Resistors High Resistance Grounding Systems. However, each unit is designed for a specific application/installation.

Please refer to the drawings supplied with your unit for ratings and other information. [Appendix A](#) contain schematics and [Appendix B](#) has dimension drawings with information for standard systems. [Figures A.1 and A.2](#) show wye-connected and delta-connected schematics respectively. Consult all specific equipment drawings furnished by Post Glover Resistors, Inc., for your particular installation.

2.1 Receiving

A preliminary inspection of the crate (or enclosure) should be made at this point to ensure that the unit was handled properly during shipment. If damage is detected, contact the carrier immediately to file a claim.

2.2 Handling

Once received, the high resistance grounding unit should be unloaded and carefully moved by overhead crane. Free-standing units have removable lifting angles for an overhead crane to use when moving the unit. Loosen and rotate the lifting angles 180°, and re-tighten before using to lift the unit. Do not attempt to move or lift the unit at points other than the lifting angles. Always store the unit upright to avoid damaging the enclosure and/or controls. Do not stack the units.

2.3 Inspection

Inspect the enclosure for any signs of shipping damage such as dents, scratches or chips. Inspect the inside of the enclosure for any loose wiring or bolts. Check the resistor for any signs of broken insulators or elements.

2.4 Storage

If the unit will be stored for some length of time, take the following precautions:

1. Remove the crate and thoroughly inspect the unit.
2. Store the unit in an area that is clean and dry and has moderate temperatures. Cover it with a heavy-duty plastic cover or cloth.
3. To prevent condensation in units stored in damp areas, provide 120-200 watts of heat for the duration of the storage period.

2.5 Floor Preparation

The equipment foundation must be designed with suitable strength and levelness. Sufficient height should be allowed above the unit to allow conduit to enter at the top of the unit if that is the desired entry point. The purchaser is responsible for anchoring the unit to the floor with anchors of suitable strength.

2.6 Grounding... CAUTION!

To reduce the possibility of electric shock, the unit must be properly grounded before making any system power connections. Connect the system ground to the ground bus. The ground bus is located in the lower portion of the free-standing units. For the wall-mount units, the ground bus is located next to the terminal block on the bottom pan of the resistor enclosure. Make sure that all ground conductors are sized per the National Electrical Code (NFPA 70).

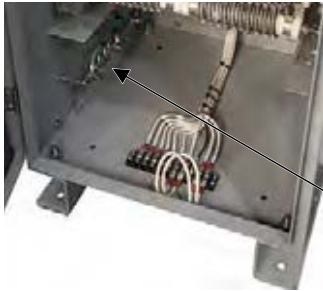

Ground Bus in a free-standing enclosure

2.7 Line and Control Connections

Refer to application specific drawings that accompany the Post Glover Resistors system. The free-standing enclosure is designed to accommodate the line cables on the sides of the enclosure without unnecessary cable bends; cable entry can be made at either the top or the bottom of the enclosure. The control power connections made to the terminal blocks are rated for 20 amperes, 600 volts and the auxiliary device connections made to the terminal blocks are rated for 5 amperes, 250 volt AC or 30 volts DC.

Refer to the specific diagrams furnished with the equipment for location detail.

As a final check, inspect all wiring to verify that connections are made properly and that they are clean and tight. Make sure there is adequate clearance between the external connections and all devices.

2.8 Setting Resistor Tap Connection

The resistor taps should to be adjusted at installation so that ground current with a ground fault is greater than or equal to the system capacitive-charging current. The procedure for determining capacitive-charging current (I_C) is described in [Section 5 – Charging Current & Resistor Tap Setting](#). Move the ground wire on the Resistor Terminal Block (TBN) to the appropriate “N” terminal such that the resistor current is greater than or equal to I_C .

NOTE: Do not connect the neutral connection (N) directly to ground. This results in a solidly grounded system and disables any benefits and protections of the HRG system.

2.9 General

When the installation is complete and all incoming wiring has been terminated, clean the inside of the unit with a soft cloth or vacuum cleaner. Make sure any dirt or debris, such as packing material, is removed so it does not interfere with the operation of the unit. Before connecting power to the control panel, check all components to make sure all shipping devices, such as blocking or tying of relays, have been removed.

Section 3 – Start-up Guide

This quick start guide provides a brief overview of the steps required to use this High Resistance Grounding Equipment, but **is not meant to be a substitute for reading the entire manual**. Please refer to [Section 4](#) for setting suggestions or reasons to change from default.

3.1 Physical Installation

Once removed from the shipping pallet and packaging, secure the unit to the floor using the provisions in the base. In one of the conduit entry areas noted on the delivered unit enclosure drawings, cut an appropriate access hole to bring the three phase conductors and two neutral connections (one if not providing a separate sensing resistor neutral cable). The ground connection can be routed through the same opening or if more convenient, a second entrance can be added in another location.

NOTE: Any work performed on this unit should be done by qualified persons and must be done in compliance with national, regional, local and site-specific safety procedures. It is the responsibility of the owner to comply with all applicable electrical codes.

3.2 Pre-energization checks

Perform the following checks before energizing the HRG unit:

- Inspect the enclosure interior for connections that may have come loose in shipping.
- Check continuity of all fuses.
- Open SW1
 - Ensure that the transformer X0 is only connected to the HRG unit. SW1 Terminal 7 to the ground bus should produce ∞ , OL, resistance.
 - Check the resistance from terminal 8 of the disconnect switch to ground. This should match the drawing value for the default resistor tap. **Default 55 Ω for Tap N5**

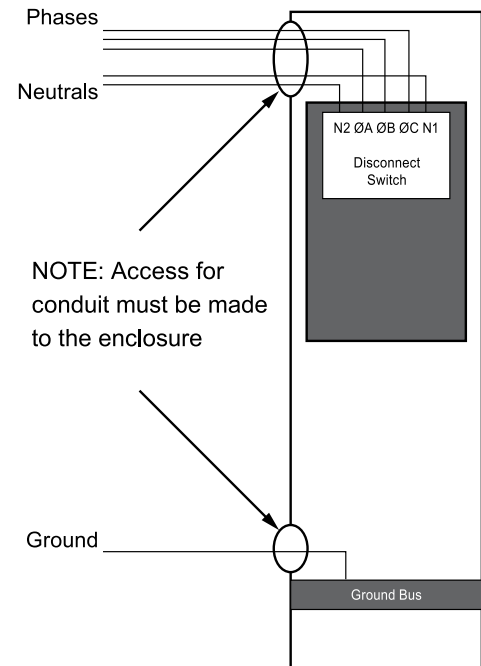

3.3 Electrical connection

Connect the three phases and neutrals to the appropriate points on the disconnect switch. **If a separate neutral is not used for the sensing resistor circuit, jumper the two neutral positions together.** Connect the internal ground bus to the system ground. See [Appendix D](#) for recommended wire sizes.

NOTE: Opening the disconnect switch removes power to the unit but also removes the grounding resistor from the circuit. The system is ungrounded while the disconnect switch is open.

PULSERPLUS.NET™ INSTRUCTION MANUAL

After the mechanical installation and all wiring is completed per specific equipment drawings furnished by Post Glover Resistors, Inc., place the system in service by following these steps:

3.3.1 Power the system by closing SW1 and control power if it is separately derived. The Home Screen will be displayed.

3.3.2 Note initial NGR Voltage and Current. When systems are first installed, any parasitic capacitance, system insulator breakdown, or fault will be evident by the NGR Voltage and Current. Normal NGR voltage is less than 5V and normal NGR current is less than 0.108A. Typically, Voltage or Current above these values indicate insulation breakdown, wet conductors, or a phase being grounded. The lower the voltage, the higher the resistance of the ground connection.

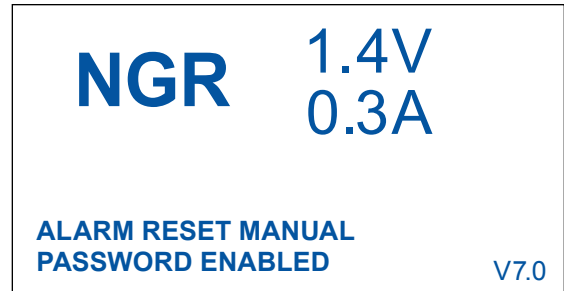

NOTE: Default NGR Voltage alarm value, VMAX, is 100V, and the default NGR Current Alarm value, IMAX, is 4A. NGR Voltage or Current above these values will produce an alarm. If there is an active fault upon power up, the alarm screen will display, the red fault light will be flashing and the alarm horn will sound. See Section 6 for a full list of alarms.

3.3.3 Press the SYSTEM INFO button to view the Status Screen.

3.3.3.1 All analog inputs monitored by the system are displayed on this screen. The NGR Current and Voltage should be in the range described above. The Sensing Resistor Volts should be very close, +/- 2.5 Volts, to the NGR Voltage. Test Resistor Current will only be present during a Ground Fault Test, or during a Charging Current Test. Once the system charging current test is performed, the information is stored here.

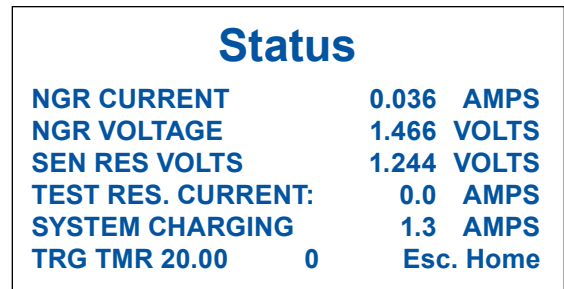

- The timer and counter on the bottom line are used for the neutral monitoring circuit.
- Press the **ESC/BACK** button to return to the home screen.

3.3.4 Set the time and date

Press and hold the **SYSTEM INFO** button for 6 seconds.

Enter the system level password "1111" press **Enter**.

Press "2" to enter the system screen.

Press "4" to enter the time and date.

Enter the correct time and date. Press **ESC/BACK** until returned to the Home Screen.

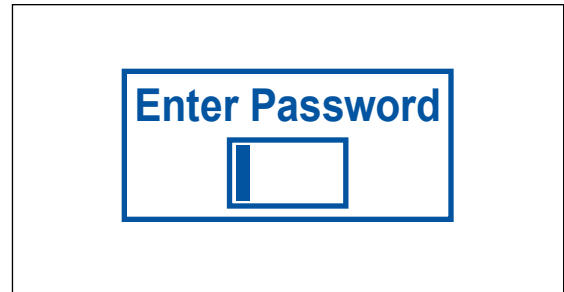

3.3.5 System Tests and Selecting and editing system parameters

To perform the System Test and change Alarm Parameters, you must disable the User Password.

Press "5" from the Home Screen.

Press "6" then press **Enter**.

Press "1000" then **Enter**.

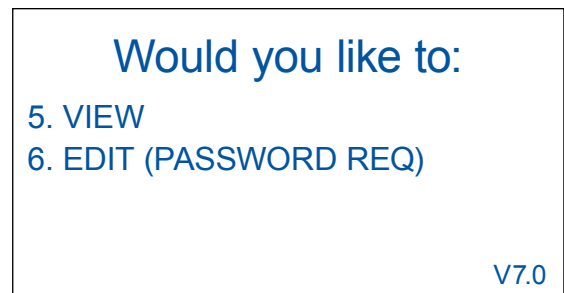

3.3.6 Perform System Tests

The system test buttons will only operate from the Edit Setup Menu. Prior to performing a ground fault test, ensure the indicator lights are operational.

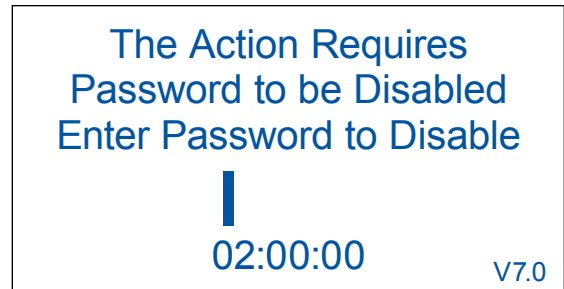

Edit Setup Menu

Setup Menu

1. NGR Alarm Values
2. System Timer Values
3. Operator Modes
4. Communications
5. Password Management



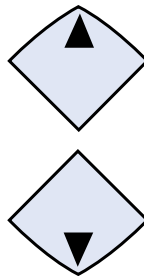

Setup Menu

5. Password Management
6. Sensing Resistor Values
7. Test (Ground Fault)
8. System Charging Current
9. Lamp Test



3.3.6.1 Lamp Test

Press and hold “9” from the Edit Setup Menu.

While the Lamp Test button is held down, the indicator lights will flash on and off, indicating the light is functioning.

3.3.6.2 Ground Fault Test

Press “7” from the Edit Setup Menu.

Note the NGR Voltage and Current Levels during the test.

With Default Settings, 1 or 2 faults should be generated during the test after the time delay has been exceeded. The Fault Light should be flashing and the alarm horn sounding.

To silence the alarm, press “2”

When the test is completed:

- The alarm screen will be displayed. Verify the following alarms have occurred (scroll using the Up/Down arrows):
 - VOLTAGE ACROSS THE NGR HAS EXCEEDED MAXIMUM (This alarm must occur to confirm test)
 - LOSS OF VOLTAGE ON PHASE C (This alarm may occur depending on system size and load)

After the alarms have been verified and 10 seconds has passed since the test has completed:

- Press the **System Reset** button.
 - The Fault Light will clear and the Enable light will be on.
- Press the **ESC/BACK** key two times to return to the Home Screen.

Press the **Menu** button to return to the Setup Menu - Edit

NEUTRAL	134.0 VOLTS
	2.4 AMPS
GROUND FAULT TEST	
TEST RESISTOR CONNECTED	
14.39 SEC.	
V7.0	

WARNING! VOLTAGE ACROSS NGR
EXCEEDED MAXIMUM ALARM VALUE.

DATE: 12/20/17	NGR Volts	112.1 V
TIME: 14:34:25		
ALARM 10		ALARMACK.

PULSERPLUS.NET™ INSTRUCTION MANUAL

3.3.6.3 System Charging Current

Press “8” from the Edit Setup Menu.

While the 5 second test takes place the SYSTEM CHARGING CURRENT IS BEING CALCULATED Screen will be displayed. When the test is complete the Charging Current Results Screen will be displayed. See Section 5.1 for details of System Charging Current.

NOTE: The System Charging Current is a critical test and is used to determine the NGR Tap Setting as well as the minimum IMAx setting. See Section 4.5.1.4 and 5.2 Resistor Tap Setting.

3.3.6.4 NGR Alarm Values

Press “1” from the Edit Setup Menu.

Use the right and left arrow buttons to move to the desired parameter to change. Note the whole numbers are selectable and the decimal places are selectable for change. When the variable you want to change is highlighted, press the **Enter** key. The value will then flash and is ready to be changed. Use the number keys to change the value, then press **Enter**.

When finished, press **ESC/BACK** to return to the Edit Setup Menu.

3.3.6.5 System Timer Values

Press “2” from the Edit Setup Menu.

Use the right and left arrow buttons to move to the desired parameter to change. Note the whole numbers are selectable and the decimal places are selectable for change. When the variable you want to change is highlighted, press the **Enter** key. The value will then flash and is ready to be changed. Use the number keys to change the value, then press **Enter**.

When finished, press **ESC/BACK** to return to the Setup Menu.

SYSTEM CHARGING CURRENT IS BEING CALCULATED.	
NEUTRAL VOLTAGE:	134.0 VOLTS
NEUTRAL CURRENT:	2.4 AMPS
TEST RES. CURRENT:	2.5 AMPS

SYSTEM CHARGING	2.2 AMPS
	V7.0

VACTUAL	1.4	VMAX	100.0
IACTUAL	0.1	VMIN	0.0
		VRATED	480.0
		IMAX	4.0
		IMIN	0.0
		IRATED	10.0
			V7.0

PULSE RATE (5-10sec)	5SEC.
GROUND FAULT TEST TIMER (1-30 sec)	10SEC.
ALARM RESEND TIMER (0-60 min)	20MIN.
TEST RESISTOR TIMER (1-30 sec)	20SEC.

3.3.6.6 Operation Modes

Press “3” from the Edit Setup Menu.

3.3.6.6.1 Enable/Disable Line Voltage Monitoring Mode

Press “1” from the Operating Modes Menu.

Press up arrow to Enable or press down arrow to Disable Line Voltage Monitoring.

When finished, press **ESC/BACK** to return to the Operating Modes Menu.

When finished, press **ESC/BACK** two times to return to the Setup Menu.

3.3.6.6.2 Enable/Disable NGR Monitor Control

Press “2” from the Operating Modes Menu.

Press up arrow to Enable or press down arrow to Disable Open Circuit Monitoring.

When finished, press **ESC/BACK** to return to the Operating Modes Menu.

When finished, press **ESC/BACK** two times to return to the Setup Menu.

3.3.6.6.3 Alarm Auto/Manual Reset Control Mode

Press “3” from the Operating Modes Menu.

Press up arrow to set Alarm Mode to Automatic or Press down arrow to set Alarm Mode to Manual.
[See Section 4.5.3.3](#)

When finished press **ESC/BACK** two times to return to the Setup Menu.

Operating Modes

1. LVM Mode
2. NGR Monitor Control
3. Alarm Auto/Manual Reset

Esc. Setup

V7.0

**PRESS UP ARROW TO ENABLE
LINE VOLTAGE MONITORING**

**PRESS DOWN ARROW TO DISABLE
LINE VOLTAGE MONITORING**

LINE VOLTAGE MONITORING ON

**PRESS UP ARROW TO TURN NGR
OPEN CIRCUIT MONITORING ON**

**PRESS DOWN ARROW TO TURN NGR
OPEN CIRCUIT MONITORING OFF**

NGR MONITORING ON

**PRESS UP ARROW TO PLACE
ALARM IN AUTOMATIC RESET MODE**

**PRESS DOWN ARROW TO PLACE
ALARM IN MANUAL RESET MODE**

ALARM IN AUTOMATIC RESET MODE

3.3.6.7 Sensing Resistor Values

Press “6” from the Edit Setup Menu.

Use the up and down arrows to scroll through all parameters. See Sections 4.5.4 for Sensing Resistor Value variable functionality. See Appendix E Setup Form for Sensing Resistor Variable value ranges.

When finished, press **ESC/BACK** to return to the Setup Menu.

SENSING RESISTOR PARAMETERS		
SENSING RES. VOLTS	0.0	VOLTS
NGR VOLTAGE	0.0	VOLTS
NGR CURRENT	0.0	AMPS
NEUTRAL VOLT VAR	10.000	VOLTS
NEUTRAL CURR VAR	0.075	AMPS
DELTA VARIABLE	5	
SENSING RES. TRGR.	17	VOLTS

SENSING RESISTOR PARAMETERS		
NGR CURRENT	0.0	AMPS
NEUTRAL VOLT VAR	10.000	VOLTS
NEUTRAL CURR VAR	0.075	AMPS
DELTA VARIABLE	5	
SENSING RES. TRGR.	17	VOLTS
OPEN NGR MIN AMP	0.037	AMPS
VOLT PULSE ACTIVE	10.000	VOLTS

Section 4 – Operational Description

4.1 HRG Function

The Post Glover Resistors PP.Net High Resistance Grounding System Equipment (HRG) coordinates the use of resistors and monitoring devices to create a high resistance ground for a power system. When a phase to ground fault occurs, the Neutral Grounding Resistor (NGR) limits the fault current. The monitoring components display, log, and can communicate information pertaining to the fault and system events. The information can be viewed on the local User Interface or over the facility network.

4.2 Home Screen

The PLC/User Interface is used to monitor, setup, test, communicate, and provide diagnostic tools for the PP.Net HRG. The Home Screen will be displayed upon power up.

4.2.1 The top of the Home Screen displays the NGR Voltage and NGR Current.

4.2.2 Active faults are displayed in the middle of the home screen.

4.2.3 Multiple faults will be displayed one at a time and with a 3 second display period.

4.2.4 The Alarm Mode is displayed on the first line of text in the lower left corner.

4.2.5 The Password Status is displayed on the second line of text in the lower left corner.

4.2.6 When the password is disabled, a setable timer will display showing how much time is left before the password automatically re-enables. This prevents leaving the system open for unauthorized changes. The time remaining before the password re-enables is to the right of the password status.

4.2.7 The software version is displayed in the lower right corner of the Home Screen.

NGR 1.4V
0.3A

FAULTED PHASE B
ALARM RESET AUTO
PASSWORD DISABLED 01:35:42 V7.0

4.3 Alarm Screen

4.3.1 From the Home Screen, pressing the **Alarm View “1”** button accesses the Alarms and Events Logging menu. See [Section 6 for Alarms and Events Management](#).

Alarms & Events

F1. Alarms
F2. Events

3. Clear All Alarms & Events

4.4 System Status Screen

4.4.1 From the Home Screen, pressing the **SYSTEM INFO** button accesses the System Status screen.

1. All analog inputs are displayed.
2. Recorded System Charging Current is displayed.
3. The Open NGR Circuit detection trigger timer and high event counter are displayed.

Status

NGR CURRENT 0.036 AMPS
NGR VOLTAGE 1.466 VOLTS
SEN RES VOLTS 1.244 VOLTS
TEST RES. CURRENT: 0.0 AMPS
SYSTEM CHARGING 1.3 AMPS
TRG TMR 20.00 0 Esc. Home

4.5 System Setup

From the Home Screen, pressing the **Menu** button “5” allows parameters to be viewed or set through the setup menu. The following parameters have default values to allow for ease of setup. Password protected parameters can be modified to customize the system monitoring.

4.5.1 NGR Alarm Values

The NGR Alarm Values are used to determine if a ground fault has occurred or a circuit has opened. Any conductive path from the power system phase to ground will conduct zero sequence current back to the system transformer X0 through the NGR. The voltage across the NGR and the current through the NGR will be dependent upon the resistance of the phase to ground path. A direct bolted fault to ground on a 480 VAC system will produce approximately 277 VAC across the NGR. The current flowing through the NGR will be dependent upon the tap setting of the resistor bank. The default Tap N5 will allow approximately 5A of current to flow.

Setup Menu - View

1. NGR Alarm Values
2. System Timer Values
3. Operation Modes
4. Sensing Resistor Values
5. Communications

V7.0

VACTUAL	1.4	VMAX	100.0
IACTUAL	0.1	VMIN	0.0
		VRATED	480.0

		IMAX	4.0
		IMIN	0.0
		IRATED	10.0

V7.0

4.5.1.1 VMAX

The NGR Over-voltage setting (VMAX) is used to alarm when Ground Faults exist. The alarm “**VOLTAGE ACROSS THE NGR HAS EXCEEDED MAXIMUM**” will be triggered.

A Ground Fault Test with typically installed test resistors and the default NGR tap will produce more than the default setting of 100 Volts. Performing a ground fault test will display the NGR voltage present during the test. Expected Ground Fault test voltage can be calculated with the following formula.

$$V_{TEST} = (V_{L-N} / (R_{GF} + R_{T-G})) R_{GF} - 10V$$

Where: V_{TEST} is the test voltage to be temporarily entered for the Over-voltage (VMAX) setting

V_{L-N} is the line-to-neutral system voltage

R_{GF} is the resistance of the neutral grounding resistor at the chosen tap. N5 typically = 55.7 Ω

R_{T-G} is the test-to-ground resistance – see resistor drawing. Typical Test Resistor = 55.7 Ω

4.5.1.2 VMIN

The NGR Under-voltage setting, VMIN, can be used to alert when a system phase to ground resistance has been increased. An increase in phase to ground resistance will lower the NGR voltage. Setting the VMIN to a voltage level just below the Normal NGR voltage will trigger an alarm when the NGR opens or when the circuit with the phase to ground resistance is opened. The alarm “**VOLTAGE ACROSS THE NGR IS BELOW MINIMUM**” will be triggered. Setting VMIN to 0, which is the default setting, will disable this function.

PULSERPLUS.NET™ INSTRUCTION MANUAL

4.5.1.3 VRATED

Set VRATED to the system voltage. VRATED is used for the system charging current algorithm.

4.5.1.4 IMAX

The NGR Overcurrent Setting (IMAX) is used to alarm when Ground Faults exist. Set this value at the level you wish to be notified of a ground fault. The alarm “**CURRENT THROUGH THE NGR HAS EXCEEDED MAXIMUM**” will be triggered.

NOTE: The value needs to be below the maximum current permitted to flow with a direct bolted phase to ground fault, as determined by system voltage and the resistor tap setting, and above the charging current test result.

4.5.1.5 IMIN

The NGR Undercurrent Setting (IMIN) can be used to alert when a system phase to ground resistance has been increased. An increase in phase to ground resistance will lower the NGR current. The alarm “**CURRENT THROUGH THE NGR IS BELOW MINIMUM**” will be triggered. Setting IMIN to 0, which is the default setting, will disable this function.

NOTE: If IMIN is set too close to the normal system NGR current, opening a breaker to remove a portion of the system load may reduce peracetic capacitance and trigger nuisance IMIN alarms.

4.5.1.6 IRATED

Set IRATED to the maximum allowable system current allowed by the lowest resistance value on the resistor tap settings. **Default 10 Amps.**

4.5.2 System Timer Values

4.5.2.1 PULSE RATE

The pulse rate timer will determine the length of time the pulse relay is engaged. The pulse relay is used to vary the NGR resistance making it easier to find a ground fault. See [Section 7 Finding a Ground Fault for details](#). The relay will be off for the same period of time it is on. 2 to 10 seconds

The pulse function will time out and stop pulsing after 4 hours when the pulse time is between 2 to 4 seconds. The pulse function will time out and stop pulsing after 12 hours when the pulse time is between 5 to 10 seconds.

PULSE RATE (5-10sec)	5SEC.
GROUND FAULT TEST TIMER (1-30 sec)	10SEC.
ALARM RESEND TIMER (0-60 min)	20MIN.
TEST RESISTOR TIMER (1-30 sec)	20SEC.

4.5.2.2 GROUND FAULT TEST TIMER

The Ground Fault Test Timer will determine how long a fault condition exists prior to an alarm being generated.

4.5.2.3 ALARM RESEND TIMER

The Alarm Resend Timer will recycle the auxiliary alarm contacts for the “System Fault”, output 3, and the “Ground Fault”, output 4, each time this timer times out. See the Indication Matrix in 4.10 for details.

4.5.2.4 TEST RESISTOR TIMER

The Test Resistor (Ground Fault Test) is used to verify the system is working and to determine charging current. The Test Resistor Timer determines how long the Ground Fault Test will last. If the Test button is pressed during a ground fault test, the timer will reset. With the **GROUND FAULT TEST TIMER** set at 10 seconds, a normal ground fault test will produce an alarm.

4.5.3 Operational Modes

4.5.3.1 LVM Mode

The PEM module monitors all three phases of the system line voltage. If any phase falls below 50VAC, an alarm will be triggered for that phase.

4.5.3.2 NGR Monitor Control

The NGR Monitoring Control mode determines whether the Open Circuit Alarm detection is enabled or disabled.

4.5.3.3 Alarm Auto/Manual Reset

The Alarm Auto/Manual Reset mode determines how a Fault will be reset. (The default setting is “**Manual**”).

When in Manual Mode, if an alarm occurs, the horn will sound and the Fault Light will flash until acknowledged. Pressing the **ACK ALARM “2”** button will silence the horn and cause the Fault Light to stop flashing. Once the alarm clears and after the Ground Fault Test Timer times out, the alarm fault light can be cleared and the system reset by pressing the **SYSTEM RESET “0”** button. To reset the system, the alarm must not be active and the Ground Fault Test Timer must time out. You will see no active fault on the home screen.

When in Automatic Mode, any alarm that is triggered, will be reset when the alarm conditions go away, and after the Ground Fault Test Timer times out. The Fault Light will go out and the Normal Light will illuminate.

4.5.4 Sensing Resistor Values

The Sensing Resistor Values are used to determine if an Open NGR Circuit Exists.

There are three possible alarms associated with an Open NGR Circuit:

- Open NGR Circuit Alarm Active Trigger (Path 1- 3 if NGR Voltage is below Voltage Pulse Active Variable)
- Open NGR Bank (Path 3)
- Open Neutral Circuit (Path 1)
- Open Sensing Circuit (Path 2)

Operating Modes

1. LVM Mode
2. NGR Monitor Control
3. Alarm Auto/Manual Reset

Esc. Setup

V7.0

SENSING RESISTOR PARAMETERS

SENSING RES. VOLTS	0.0	VOLTS
NGR VOLTAGE	0.0	VOLTS
NGR CURRENT	0.0	AMPS
NEUTRAL VOLT VAR	10.000	VOLTS
NEUTRAL CURR VAR	0.075	AMPS
DELTA VARIABLE	5	
SENSING RES. TRGR.	17	VOLTS

4.5.4.1 NEUTRAL VOLTAGE VARIABLE

Compare the NGR Voltage to the NGR Voltage Variable. If the NGR Voltage is greater than the NGR Voltage Variable, perform a NGR Current Variable Test.

4.5.4.2 NEUTRAL CURRENT VARIABLE

If the NGR Voltage is above the NGR Voltage Variable and the NGR Current is below NGR Current Variable, then we know the NGR Circuit is open.

4.5.4.3 DELTA VARIABLE

During normal conditions, the NGR Voltage and the Sensing Resistor Voltage will be close in value. The Delta Variable is used to compare the difference between the two voltages.

4.5.4.4 SENSING RESISTOR TRIGGER

When the Sensing Resistor Voltage exceeds the sensing resistor trigger, a high trigger event is counted. The Open NGR Active Trigger alarm will be generated when four consecutive high trigger events are counted.

SENSING RESISTOR PARAMETERS		
NGR CURRENT	0.0	AMPS
NEUTRAL VOLT VAR	10.000	VOLTS
NEUTRAL CURR VAR	0.075	AMPS
DELTA VARIABLE	5	
SENSING RES. TRGR.	17	VOLTS
OPEN NGR MIN AMP	0.037	AMPS
VOLT PULSE ACTIVE	10.000	VOLTS

4.5.4.5 OPEN NGR MINIMUM AMPERAGE

If NGR Current is less than the Open NGR Minimum Current variable, we can say the NGR Current is 0. This allows for a correction to the floating raw count. 1 count = -036A.

4.5.4.6 VOLTAGE PULSE ACTIVE

The Open NGR Alarm Active Trigger operates when the NGR Voltage is below this value.

4.5.5 PASSWORD MANAGEMENT

The User Password protects against inadvertent or unauthorized testing or changing of alarm parameters. It ships with a factory default that can be changed by the end user.

Press “5” from the Edit Setup Menu.

4.5.5.1 To Disable/Enable Password from the Password Management Screen.

Press “1” from the Password Management Screen.

Password Management

1. Disable/Enable Password
2. Change Password
3. Change Time

Esc. Setup Menu

V7.0

PULSERPLUS.NET™ INSTRUCTION MANUAL

If disabled, enable the password from the Password Management screen by pressing “1” followed by the Up arrow.

Press up arrow to Enable or **ESC/BACK** to return to the Password Management Screen.

Press **ESC/BACK** to return to the Home Screen

4.5.5.2 To Change Password

Press “2” from the Password Management Menu.

Press the right arrow key to highlight the new Password then press **Enter**.

Enter the new password and be sure to record the information for safe keeping.

When finished, press **ESC/BACK** to return to the Setup Menu.

When finished, press **ESC/BACK** two times to return to the Setup Menu.

4.5.5.3 To change the length of time until the password automatically re-enables

Press “3” from the Password Management Menu.

Press **Enter**, then enter the time in Hours: Minutes: Seconds: 100th of seconds.

Press **ESC/BACK** to return to the Password Management Screen.

When finished, press **ESC/BACK** two times to return to the Setup Menu.

Password Disabled
Press UP to Enable

01:59:44

V7.0

Enter Old Password:

0

Enter Old Password:

1000

Enter New Password:

1000

Change Successful!

New Password: 1000

Press ESC to return
to Setup Menu

V7.0

Enter A New
Password Time

02:00:00:00

V7.0

4.6 System Tests

The password must be disabled to perform tests. The system test buttons will only operate from the setup menu. Only qualified persons should perform testing. **Abide by all Electrical Safe Work Practices to perform System Tests.**

4.6.1 Ground fault testing

The Ground Fault Test places a ground fault on the system using the supplied system voltage at SW1. The test relay in the PEM will close and current will flow through the test resistor bank to ground and from ground to the NGR bank, back to the system neutral.

4.6.2 Charging Current Test

Pressing the Charging Current button initiates test circuit described above to calculate the system charging current. The maximum charging current on the system will only be detected and displayed if all available circuits on the system are connected to the system. Each branch circuit must have all disconnects, breakers, or other connecting means closed.

4.6.3 Lamp Test

While pressing the Lamp Test button, the Normal, Fault, and Pulse lamps will flash. This test is used to verify the lamps are functioning properly. Perform the Lamp test prior to performing a ground fault test to ensure the proper indications will be available.

4.6.4 Open NGR Test

4.6.4.1 Pulling FU1 or FU5 will generate an Open NGR alarm after four high trigger events. The high trigger counter can be monitored on the System Status Screen. The events are counted once every 20 seconds and tested for three seconds. The alarm will take approximately 90 seconds to trigger after opening the circuit. This detection method is Active Sensing and will trigger an “Open NGR Circuit Alarm Active Trigger”.

4.6.4.2 During an elevated NGR Voltage condition, as defined by the Voltage Pulse Active Sensing Resistor Variable, Default 10V, if there is a deviation between the NGR Voltage and the Sensing Resistor Voltage of greater than the Delta Variable, default 5V, one of the NGR Neutral Circuit paths is open. The circuit path is identified in the alarm description. The NGR Bank is being monitored by the Neutral Voltage Variable, Neutral Current Variable, Delta Variable, and Open NGR Min. Amps Variables.

4.6.5 Loss of Phase Test

Phase loss testing will be dependent upon how Control Power (120VAC circuit) is supplied to your system. By removing power, pulling FU2, returning power, a phase lose fault will be generated on phase A. If your system is supplied with a system voltage CPT, pulling FU3 or FU4 will result in a PLC power loss, thereby removing all system monitoring. If the system is supplied by separately derived control power, Phase B and Phase C can also be tested.

4.7 Indicator Lights

4.8.1 Normal

- When the normal light is illuminated, the system does not detect any of the eight Alarms being monitored.

4.8.2 Fault

- Alarm Mode in manual
 - When the fault light is illuminated, one of the alarms listed in [Section 6.1](#) has occurred and not yet cleared, or is active.
- Alarm Mode in automatic
 - One of the alarms listed in [Section 6.1](#) is active.

4.8.3 Pulse

- With an active alarm other than Open NGR Circuit, pressing the **Pulse “4”** button will vary the NGR resistance, creating a current that will change. The current change will be visible as a pulse on a zero sequence amp meter. This will help locate ground faults. [See Section 7 – Locating a Ground Fault.](#)

4.8 Alarm Horn

The alarm horn sounds when a fault occurs. Press the Acknowledge Alarm button to silence the horn. The alarm horn will also sound upon power up or during a software download until the PLC code has initialized.

PULSERPLUS.NET™ INSTRUCTION MANUAL

4.10 Indication Matrix

User Interface Screen	Lamp			Output Contacts		Condition	Action
	Normal	Fault	Pulse	System Contact	Ground Contact		
Blank	Off	Off	Off	Open	Open	No control power	Turn on SW1 or external Control Power.
No Alarms	On	Off	Off	Closed	Closed	System Normal	None required.
Current Above Limit	Off	On	Off	Closed	Open	Ground Fault Present	Locate and Clear Faults. See Section 7
Current Below Limit	Off	On	Off	Open	Closed	Possible Loss of Ground	Check continuity of neutral circuit. 4 Paths <ul style="list-style-type: none"> • PEM 15 to X0 • PEM 16 to X0 • PEM 22 to GND Bus
Phase A Fault	Off	On	Off	Closed	Open	Ground Fault Present	Locate and Clear Faults. See Section 7
Phase B Fault	Off	On	Off	Closed	Open	Ground Fault Present	Locate and Clear Faults. See Section 7
Phase C Fault	Off	On	Off	Closed	Open	Ground Fault Present	Locate and Clear Faults. See Section 7
Voltage Above Limit	Off	On	Off	Closed	Open	Ground Fault Present	Locate and Clear Faults. See Section 7
Voltage Below Limit	Off	On	Off	Open	Closed	Possible Loss of Ground	Check continuity of neutral circuit. 4 Paths
Open NGR Active Trigger	Off	On	Off	Open	Closed	Possible Loss of Ground	Check continuity of neutral circuit. 4 Paths
Open NGR Blank	Off	On	Off	Open	Closed	Possible Loss of Ground	Check continuity of neutral circuit. <ul style="list-style-type: none"> • PEM 22 to NGR N • NGR Tap to GND Bus
Open NGR Neutral Circuit	Off	On	Off	Open	Closed	Possible Loss of Ground	Check continuity of neutral circuit. <ul style="list-style-type: none"> • PEM 15 to X0
Open NGR Sensing Circuit	Off	On	Off	Open	Closed	Possible Loss of Ground	Check continuity of neutral circuit. <ul style="list-style-type: none"> • PEM 16 to X0

Section 5 – Charging Current & Resistor Tap Setting

5.1 System Charging Current

5.1.1 General

In ungrounded systems, a voltage is held on the system capacitance after a fault. In an arcing or intermittent fault, this can lead to a significant voltage build-up. In a high resistance grounded system, the resistance must be low enough to allow the system capacitance to discharge, thereby preventing significant voltage build-up.

The magnitude of zero-sequence charging current is determined by the line-to-ground capacitance associated with system components. The value of this current must be known to properly coordinate the Post Glover Resistors High Resistance Grounding System. In an industrial power system where the design and components are known, the charging current can be estimated with reasonable accuracy. With a complex array of machines and cables, this may be tedious and yield less-than-accurate results.

During the startup procedure, a System Charging Current Test will be performed. The system charging current will be used to determine the NGR tap setting, which in turn determines current permitted to flow during a ground fault. [See Section 5.2 for details.](#)

5.1.2 System Charging Current Test

The most accurate way to determine the maximum value of the charging current is by test, since extreme variations can exist. The charging current per phase is represented by I_{CA} , I_{CB} or I_{CC} , while I_C corresponds to the total line-to-ground charging current. To obtain the zero-sequence charging current, one phase conductor is intentionally grounded as shown in the schematic below. **The test should be performed with all system equipment connected and in the circuit.** Repeating the charging current test is necessary with a significant system change.

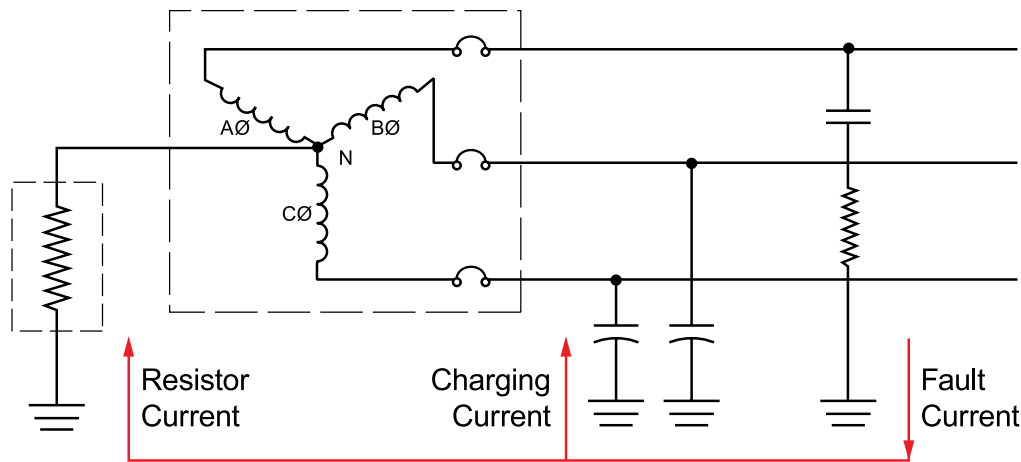

$$I_C = \frac{V_{RATED}}{\sqrt{3}V_R} \sqrt{I_F^2 - I_R^2}$$

V_{RATED} = System Voltage taken from System Values Screen

V_R = Measured Resistor Voltage

I_F = Fault current measured at test resistor

I_R = Measured Grounding Resistor Current

5.1.3 Test Results

The resulting value is to be used to determine the minimum current for ground fault alarming, meaning the IMAX setting in the NGR Alarm Value settings should not be below the System Charging Current Results.

5.2 Resistor Tap Connection

The resistor taps need to be adjusted at installation so that ground current with a ground fault is greater than or equal to the system capacitive-charging current.

Check the resistance from terminal 8 of the disconnect switch (SW1) to ground. This should match the drawing value for the default resistor tap. The resistor taps are labeled with a “N” and a number: N2, N3, N4, N5, N6, N8, N10. The corresponding number is the pre-determined amperes that will be allowed to flow during a bolted fault. Single Phase voltage to Ground, divided by the NGR resistance value measured from terminal N5 to ground, will verify the expected ground fault current.

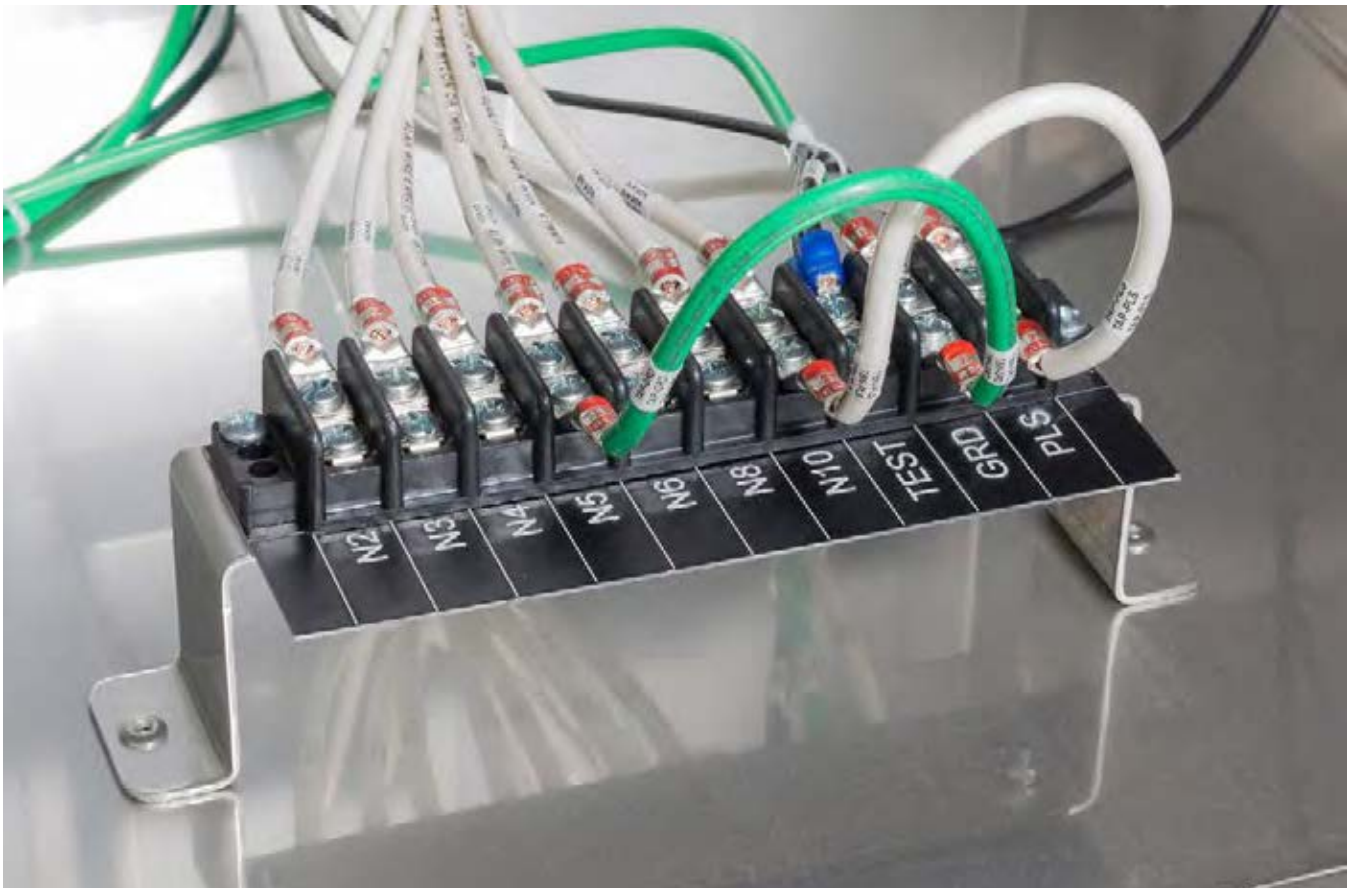

Section 6 – Troubleshooting

Alarms and Events

The Alarm and Event information will log which alarm or event has occurred, when it occurred, what the values detected were at the time, and when the system returned to a normal state.

6.1 Alarms (Records 200 Alarms with FIFO Event Management)

- 6.1.1 VOLTAGE ACROSS THE NGR HAS EXCEEDED MAXIMUM
- 6.1.2 VOLTAGE ACROSS THE NGR IS BELOW MINIMUM
- 6.1.3 CURRENT THROUGH THE NGR HAS EXCEEDED MAXIMUM
- 6.1.4 CURRENT THROUGH THE NGR IS BELOW MINIMUM
- 6.1.5 LOSS OF VOLTAGE ON PHASE A
- 6.1.6 LOSS OF VOLTAGE ON PHASE B
- 6.1.7 LOSS OF VOLTAGE ON PHASE C
- 6.1.8 Open NGR Circuit Alarm Active Trigger
- 6.1.9 Open NGR Bank
- 6.1.10 Open Neutral Circuit
- 6.1.11 Open Sensing Circuit

6.2 Alarm Auto/Manual Reset

The Alarm Auto/Manual Reset mode determines how a Fault will be reset. (The default setting is “**Manual**”.)

When in Manual Mode, if an alarm occurs, the horn will sound and the Fault Light will flash until acknowledged. Pressing the **ACK ALARM “2”** button will silence the horn and cause the Fault Light to stop flashing.

Once the alarm clears and after the Ground Fault Test Timer times out, the alarm Fault Light can be cleared and the system reset by pressing the **SYSTEM RESET “0”** button. To reset the system, the alarm must not be active, and the Ground Fault Test Timer must time out, You will see no active fault on the home screen.

When in Automatic Mode, any alarm that is triggered will be reset when the alarm conditions go away and after the Ground Fault Test Timer times out. The Fault Light will go out and the Normal Light will illuminate.

6.2.1 Clearing Alarms and Events

The password must be disabled to clear alarms and events.

Alarms and events can be cleared one at a time with the **CLEAR ALARM “3”** button after the most recent alarm is Acknowledged. Do this from the displayed alarm page.

The entire Alarms and Events logs can also be cleared from the alarms and events page. Pressing the **CLEAR ALARM “3”** button will display the Clear Options Screen. Pressing **F1** will clear all alarms, and pressing **F2** will clear all events.

PULSERPLUS.NET™ INSTRUCTION MANUAL

6.3 Alarm Table

Alarm Name	Setting	Alarm IF	Section
VOLTAGE ACROSS THE NGR HAS EXCEEDED MAXIMUM	VMAX setting in NGR Values Menu	NGR Voltage Exceeds VMAX	4.5.1.1
VOLTAGE ACROSS THE NGR IS BELOW MINIMUM	VMIN setting in NGR Values Menu	NGR Voltage Falls Below VMIN	4.5.1.2
CURRENT THROUGH THE NGR HAS EXCEEDED MAXIMUM	IMAX setting in NGR Values Menu	NGR Current Exceeds IMAX	4.5.1.4
CURRENT THROUGH THE NGR IS BELOW MINIMUM	IMIN setting in NGR Values Menu	NGR Current Falls Below IMIN	4.5.1.5
LOSS OF VOLTAGE ON PHASE A	PEM monitored Phase A voltage	Phase A Voltage drops below 50 VAC	4.5.3.1
LOSS OF VOLTAGE ON PHASE B	PEM monitored Phase B voltage	Phase B Voltage drops below 50 VAC	4.5.3.1
LOSS OF VOLTAGE ON PHASE C	PEM monitored Phase C voltage	Phase C Voltage drops below 50 VAC	4.5.3.1
Open NGR Circuit - 4 alarms – 3 Possible Paths	Neutral Circuit Paths <ul style="list-style-type: none"> • PEM 15 to X0 • PEM 16 to X0 • PEM 22 GND Bus 	Alarm if an open circuit is detected in any of the three paths. Detection Methods: <ul style="list-style-type: none"> • Active Trigger – 24VDC pulse • NGR Volts and Amps Monitoring • Sensing Resistor Volts Monitoring 	Open NGR General
Open NGR Circuit Alarm Active Trigger	<ul style="list-style-type: none"> • Sensing Resistor Trigger • Volts Pulse Active 	Four consecutive high trigger events are counted. See Status Screen Press SYSTEM INFO from Home Screen	Error! Reference source not found. 4.5.4.4
Open NGR Bank	<ul style="list-style-type: none"> • Delta Variable • Neutral Current Variable • Neutral Voltage Variable • Open NGR Min Amp 	Detection of lower than expected current flow at a determined and confirmed voltage level.	4.5.4.1 4.5.4.2 4.5.4.5
Open Neutral Circuit	<ul style="list-style-type: none"> • Delta Variable • Open NGR Min Amp 	Neutral Current monitored and confirmed voltage level	4.5.4.3 4.5.4.5 4.6.4.2
Open Sensing Circuit	<ul style="list-style-type: none"> • Delta Variable 	Confirmed voltage level	4.5.4.3 4.6.4.1 4.6.4.2

6.4 Events (Records 200 Events with FIFO Event Management)

Events are viewed from the Alarms and Events Screen. Press the View Alarms button. Select **F2** to view recorded events, or from the alarm list, pressing **F2** will move to the events list. The events recorded are self-explanatory and are listed below.

- 6.4.1 Loss of voltage fault is no longer detected
- 6.4.2 System Charging Current has been calculated
- 6.4.3 Test Resistor has been connected
- 6.4.4 Voltage across the NGR has returned to normal
- 6.4.5 Current Thru the NGR has returned to normal
- 6.4.6 Pulsing of faulted system through NGR has started
- 6.4.7 Pulsing of faulted system through NGR has stopped
- 6.4.8 Password has been changed
- 6.4.9 Password disabled. Protection removed from system
- 6.4.10 Password enabled. Protection restored to system
- 6.4.11 Front Panel Lamps and Horn Tested
- 6.4.12 Loss of voltage monitoring disabled
- 6.4.13 Loss of voltage monitoring enabled
- 6.4.14 Open NGR monitoring disabled
- 6.4.15 Open NGR monitoring enabled
- 6.4.16 HRG alarm system in manual reset mode
- 6.4.17 HRG alarm system in auto reset mode
- 6.4.18 NGR Open Circuit Returned to normal

6.5 General

The voltage and current measurement of the Neutral Grounding Resistor (NGR) is the primary function of the HRG monitoring system. The four alarms available are generated by these measurements.

The phase voltage monitoring on the HRG can help determine which phase has faulted. A bolted fault will take the faulted phase voltage below 50VAC and will trigger a phase loss alarm.

The Open NGR detection circuit monitors the health of the NGR circuit. There are three paths being monitored, both in active mode, meaning with no fault present less than 10V on the NGR, and in passive mode, meaning with voltage and current on the NGR. There is one active trigger mode alarm, and three passive alarms, one associated with each path.

When the HRG is connected to a plant system, the NGR Voltage should be less than 10V. There may be some leakage to ground. The leaking component can be parasitic capacitance, power electronic components with some breakdown, common mode EMI filters, motor shaft current, insulator contamination, conductor insulation breakdown, or other. When a fault exists, the fault resistance is placed in series with the NGR.

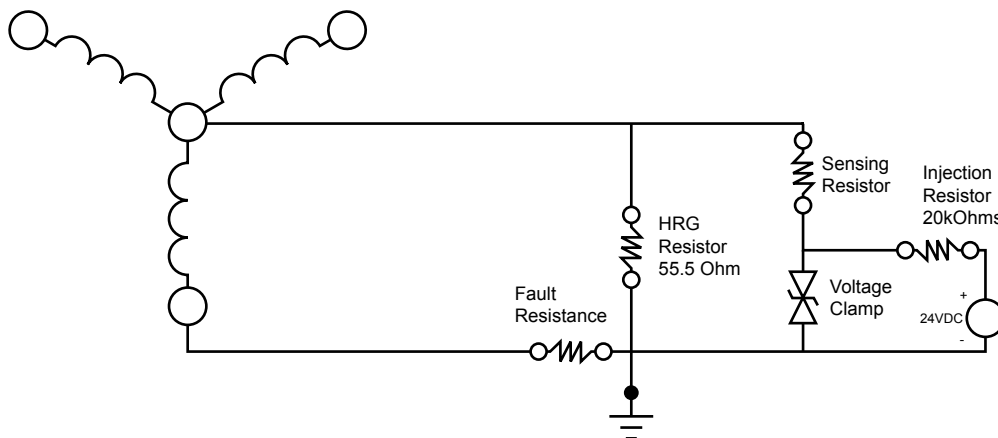

6.6 Troubleshooting by Symptom

6.6.1 Fault Light on:

1. When a fault has occurred, an alarm will be displayed and recorded.
2. Active faults are displayed in the middle of the Home Screen. Determine if the fault is still active.
3. If the fault is not active, an event will be recorded, indicating when the fault condition returned to normal.
4. The Alarm Table above identifies which parameter setting is being used to trigger the alarm and “Alarm If” information.
5. Many ground faults will have two or three alarms associated with the fault: Max Voltage, and or Max Current, and or Phase loss. For active Ground Faults, refer to [Section 7 Locating a Ground Fault](#).

6.6.2 No information on Display:

1. Is 24VDC power available? Check the voltage at the power supply output terminals with the disconnect switch in the ON position. If there is no voltage present, check the fuses and the source 120VAC power.
2. Is the controller power cable secure? Verify that the connection between the controller and base panel is firmly connected.
3. If both of the above check out OK, consider replacing the controller.

6.6.3 Normal light will not illuminate:

1. Is the Red Ground Fault Light blinking? If so, locate and clear the fault and press the SYSTEM RESET button.
2. Is the pulsing light illuminated? If so, press the **PULSE “4”** button to exit out of pulse mode.
3. Is there an under-voltage or undercurrent condition? Check the NGR voltage and current low limit settings. Also, check the continuity of the HRG circuit from X0 to Ground.
4. Check the K2 relay. If the light is not lit, check for loose wires from controller output terminal 4.
5. If K2 is lit, check for loose wires at PL1 (green light). If none are found, consider replacing the lamp.

6.6.4 TEST button does not seem to function properly (no alarm):

1. Verify password has been entered.
2. Do the voltage and current readings on the display increase?
 - a. If so, the High Limits may need to be lowered for the fault to register.
 - b. If not, there may be an installation issue, such as the Neutral wire for the HRG not connected to X0 on the transformer.
3. Is there heat coming from the test resistor? Check by feeling for warm air from the exhaust vent of the resistor enclosure. If there is heat and there is no voltage and current reading on the NGR, this condition is indicative of a solidly-grounded neutral. Check the transformer X0 bushing and the switchgear to make sure that all connections between neutral and ground are removed.

For further assistance, press the **HELP** button, and use the contact information provided to contact Post Glover Resistors.

When contacting Post Glover Resistors, please provide the following:

1. The name/type of alarm
2. The SO Number for the equipment, which can be found on the black label on each Post Glover Resistors Unit
3. Any details which may be pertinent

For Assistance, call
800-537-6144 (US)
859-283-0778; or email
sales@postglover.com

SOFTWARE VERSION

V7.0

Section 7 – Locating a Ground Fault

To locate a ground fault, activate the pulsing circuit by pressing the **PULSE** button on the operator’s panel. The pulsing circuit cannot be enabled unless there is a ground fault detected by the PulserPlus.Net. After pressing the button, the controller will display the “Pulser Running” screen. This screen shows the pulse rate in seconds and the neutral voltage and current. This activates a control circuit which causes a cyclic switching sequence. The switching sequence consists of the cycle timing of an integral pulsing relay (PX). The pulsing relay (PX) shorts out a portion of the grounding resistor (NGR) each time the relay is energized, producing a tracer signal.

The optional portable hook-on detector is then used to follow the tracer signal through the system to the point of the fault. The detector is clamped around all three phases of each individual feeder (see the schematic below). The feeder with the fault will show rhythmic fluctuations on the detector’s readout. The fault can be traced to the sub-feeder and eventually to the faulted device. Once this location is determined, the pulsing contactor should be turned off by pressing the **PULSE** on the operator’s panel. This will return the user to the “System Status” screen.

After clearing the fault, place the system in its normal operation mode by pressing the **SYSTEM RESET** button.

NOTE: A portable ammeter can be included as an option with the PulserPlus.Net.

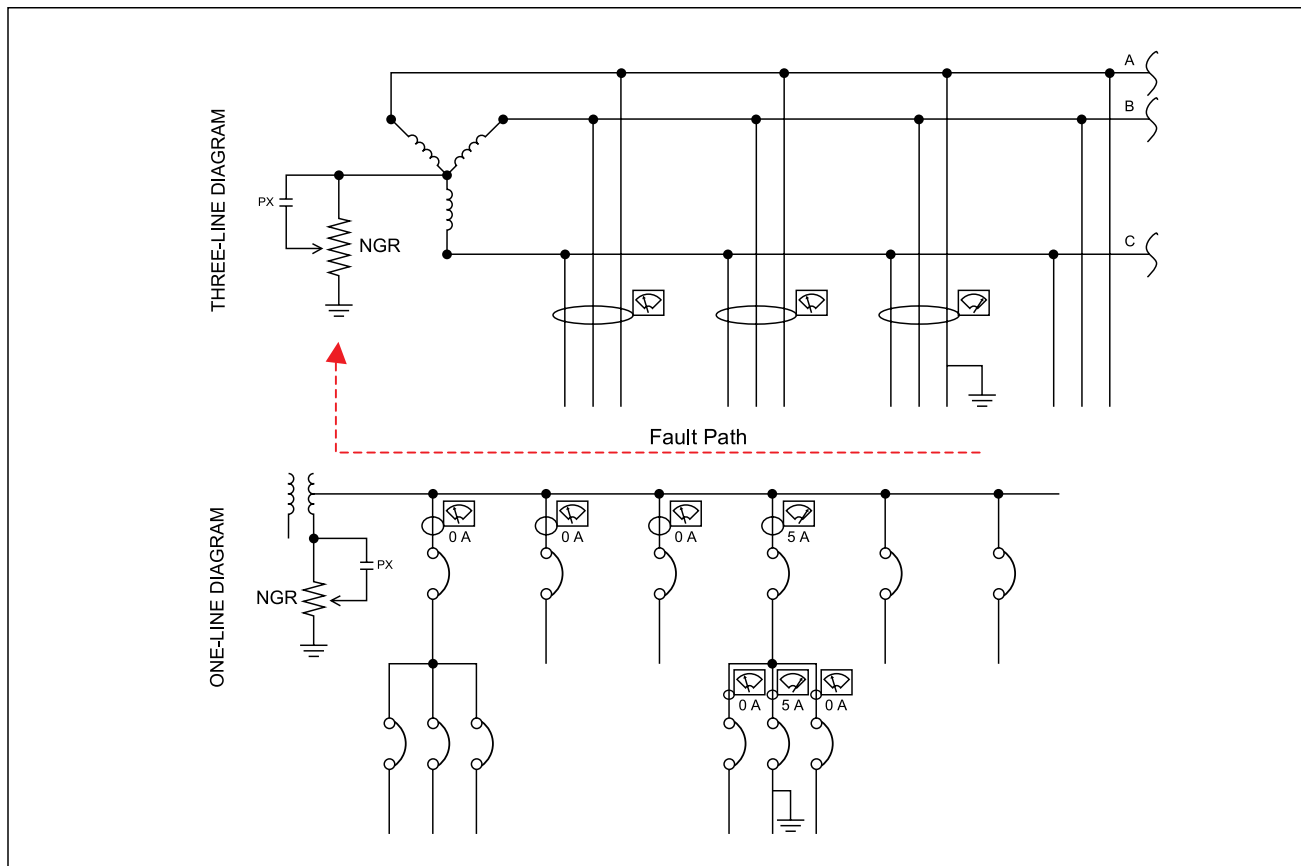

How to Locate a Ground Fault

Section 8 – User Interface

PulserPlus.Net™ Controller Faceplate Layout

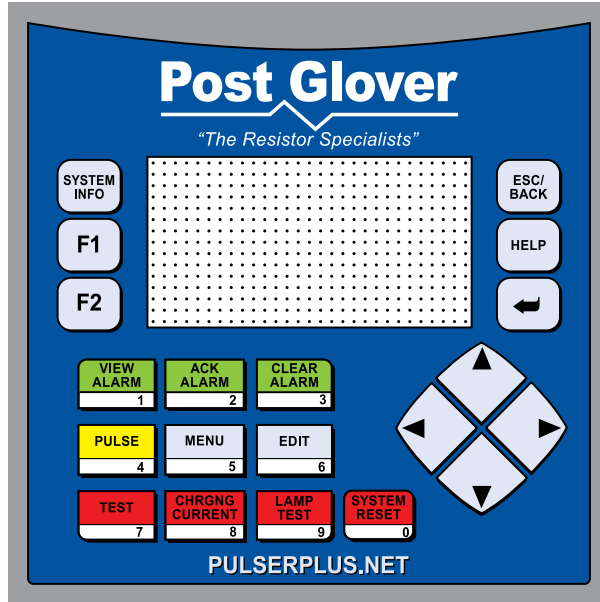

8.1 Navigation Keys

<u>Key</u>	<u>Function</u>
SYSTEM INFO	This is the system information button. When pressed and released, the status screen is displayed. When held for 5 seconds and a password is input, the system information screens are accessed.
F1	This key is used for moving between screens as indicated on the display.
F2	This key is used for moving between screens as indicated on the display.
ESC/BACK	Back function: when the user is viewing a screen, the user is taken back to the previous screen. ESC function: when the user is editing data, data entry is aborted and the original value is redisplayed.
HELP	Pressing this key displays the screen containing Post Glover Resistors' websites and phone numbers.
Enter	This key is used for accessing a data point for editing and for saving the data point after editing.
Arrows	The four arrow keys are used for two purposes: <ol style="list-style-type: none"> 1. When in View Alarms or View Events, scroll through alarm or event screens. 2. When in data entry mode, move among user-editable data items.

PULSERPLUS.NET™ INSTRUCTION MANUAL

8.1.1 Function and Digit Keys

The following table describes the color coded buttons, their associated numeric values and a description of the operation performed when pressed. The numeric value is used when data points are being edited or for selecting a sub-menu.

Button Label	Digit = # entry	Password	Operation
VIEW ALARM	1	Not required	From the home screen, when pressed, this button opens the screen controlling access to the alarms and events screens.
ACK ALARM	2	Not Required	This button is used to acknowledge the currently displayed alarm or event and to silence the alarm horn from the home screen or the alarm screen.
CLEAR ALARM	3	Required	This button is used to clear the currently displayed alarm or event. When pressed, this record is permanently removed from either the alarm or event data tables.
PULSE	4	Not Required	Upon pressing this button, the closing and opening of the pulse contactor is initiated. Press the "PULSE" key again to stop pulsing. This button is only active in a fault condition.
MENU	5	Viewing - Not Required Editing-Required	This button is used to access the system parameters for viewing and editing. The setup is also initiated through this menu.
EDIT	6	Not Required	When pressed, the user is taken to the password entry screen. Upon successful entry of the password, the user will have access to the Setup Menu.
TEST	7	Required	From the Edit Setup Menu Screen, when pressed the test resistor contact is closed. The test resistor contact opens when the test timer times out. This feature is disabled in the event of a ground fault.
CHRGING CURRENT	8	Required	From the Edit Setup Menu Screen, when pressed, the test resistor contact is closed and the system charging current is calculated. Upon completion, the test resistor contact opens. This feature is disabled in the event of a ground fault.
LAMP TEST	9	Required	When pressed and held, all front panel lamps turn on and off. The lights return to normal condition when the Lamp Test Button is released.
SYSTEM RESET	0	Required	When pressed, all alarm states are reset and the green "NORMAL" lamp turns on.

8.2 PP.Net V7.X Menu System

8.2.1 Home Screen:

8.2.1.1 NGR voltage and Current is monitored.

8.2.1.2 All Active alarms are displayed.

8.2.1.3 The Alarm Mode is displayed.

8.2.1.4 The Status of Password Protection is displayed as well as the time remaining before Password protection Self Enables/Times Out.

8.2.1.5 The Software Version is displayed.

8.2.1.6 Pressing **ESC/BACK** returns to the previous screen. A maximum of three pushes of the **ESC/BACK** button will return to the Home Screen from any location in the software.

8.2.2 Alarms & Events Screen

8.2.2.1 From the Home Screen, pressing the **ALARM VIEW "1"** button accesses the "**Alarms and Events**" logging menu.

NGR 1.4V
0.3A

ALARM RESET MANUAL
PASSWORD ENABLED

V7.0

NGR 1.4V
0.3A

FAULTED PHASE B
ALARM RESET AUTO
PASSWORD DISABLED 01:35:42

V7.0

Alarms & Events

F1. Alarms

F2. Events

3. Clear All Alarms & Events

8.2.3 System Status Screen

8.2.3.1 From the Home Screen, pressing the **SYSTEM INFO** button accesses the System Status screen.

8.2.3.2 All four analog inputs are displayed.

8.2.3.3 Recorded System Charging Current is displayed.

8.2.3.4 Open NGR Circuit detection trigger timer and high even counter are displayed.

8.2.4 Parameter View or Edit Selection Screen

8.2.4.1 From the Home Screen, pressing the **MENU “5”** button opens the Screen allowing access to the Setup Menu for viewing or edits.

8.2.4.2 Viewing parameters does not require a password and allows access to users who want to view but not change parameters.

8.2.4.3 Editing parameters does require a password and opens access to the System Tests, Setup Menus, and Password Management.

- In the password entry screen, press the **Enter** key, type in the password (default is 1000) and press the **Enter** key again.

Status

NGR CURRENT	0.036	AMPS
NGR VOLTAGE	1.466	VOLTS
SEN RES VOLTS	1.244	VOLTS
TEST RES. CURRENT:	0.0	AMPS
SYSTEM CHARGING	1.3	AMPS
TRG TMR 20.00	0	Esc. Home

Would you like to:

5. VIEW
6. EDIT (PASSWORD REQ)

V7.0

8.3 Screen Navigation Flowchart

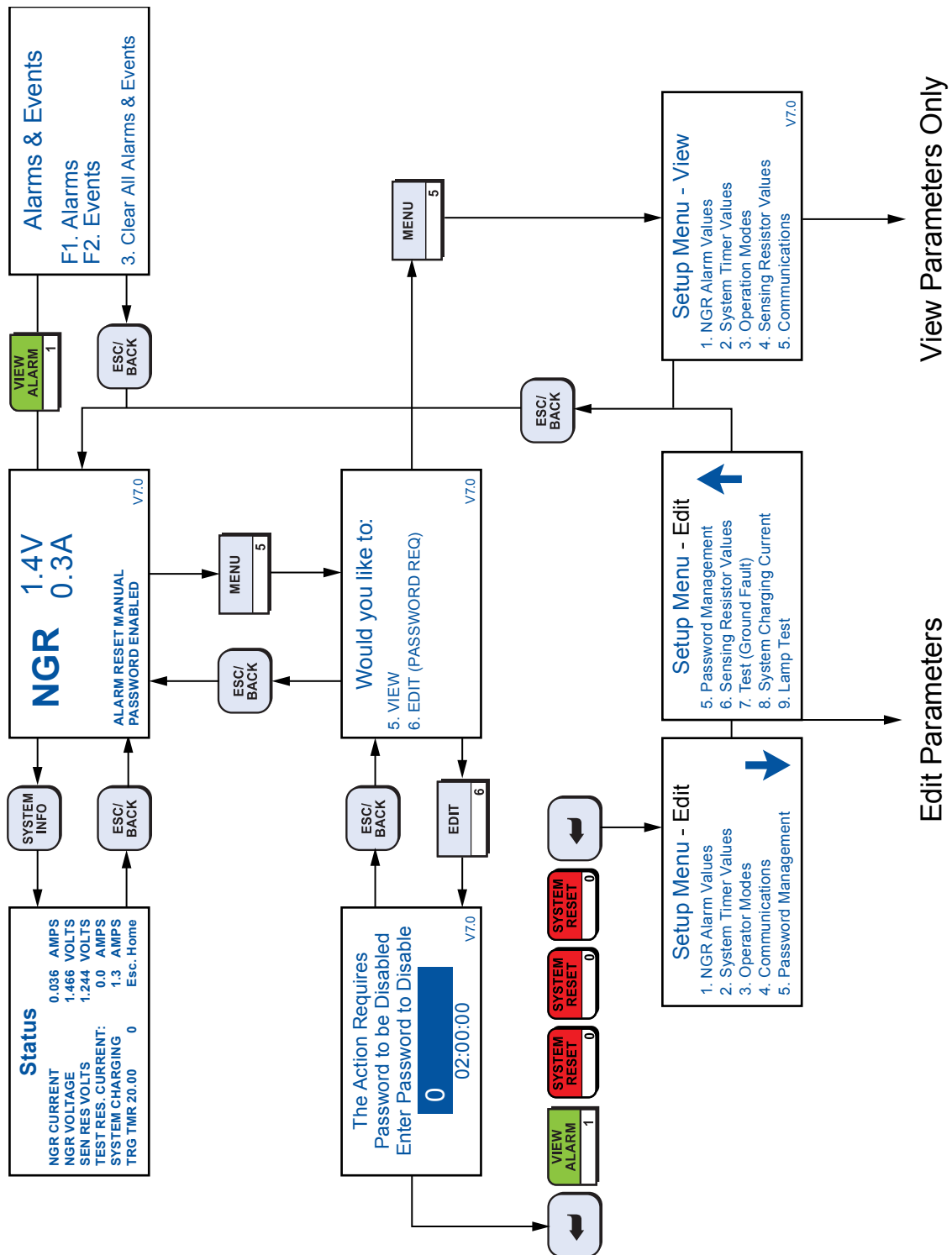

PULSERPLUS.NET™ INSTRUCTION MANUAL

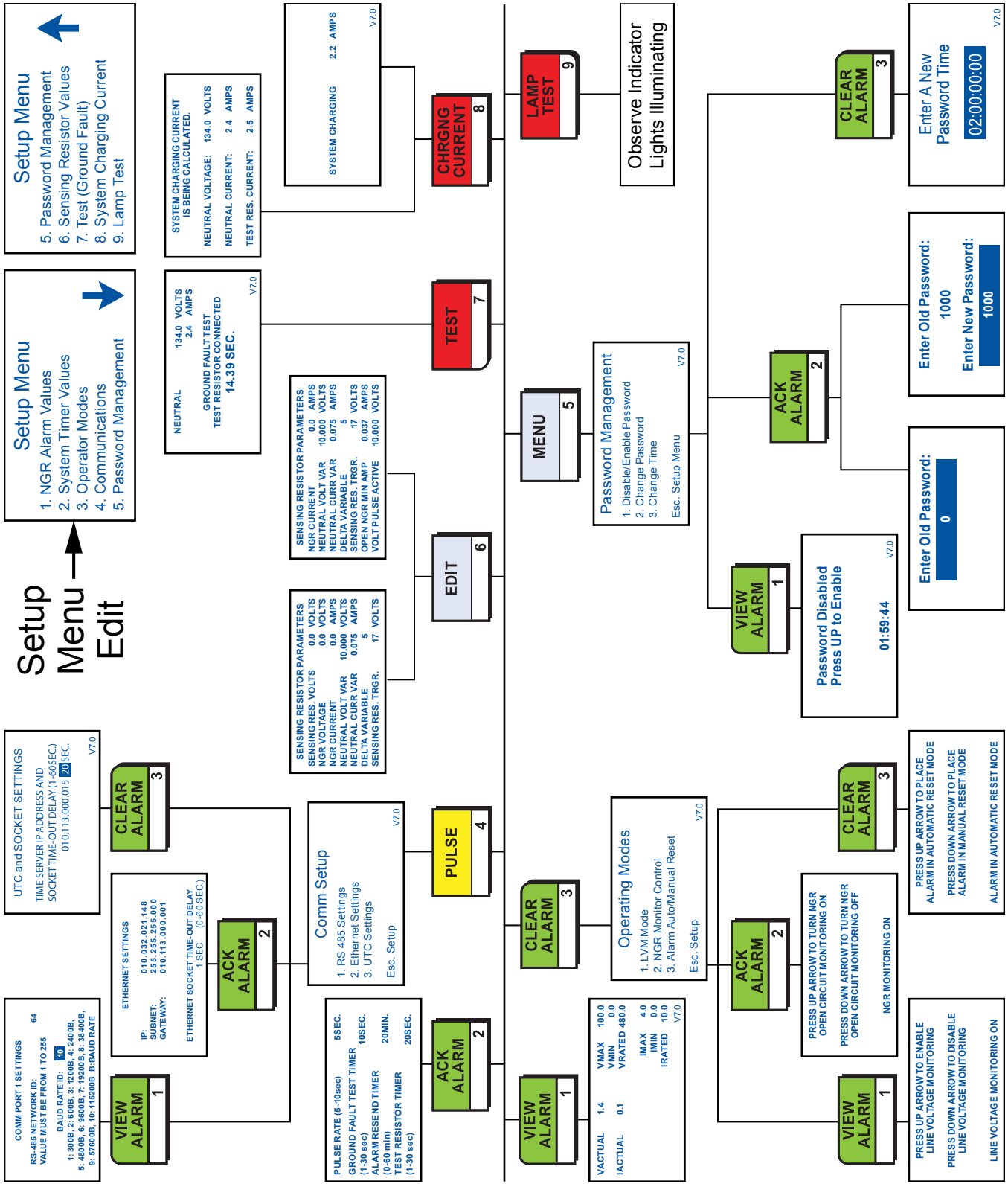

PULSERPLUS.NET™ INSTRUCTION MANUAL

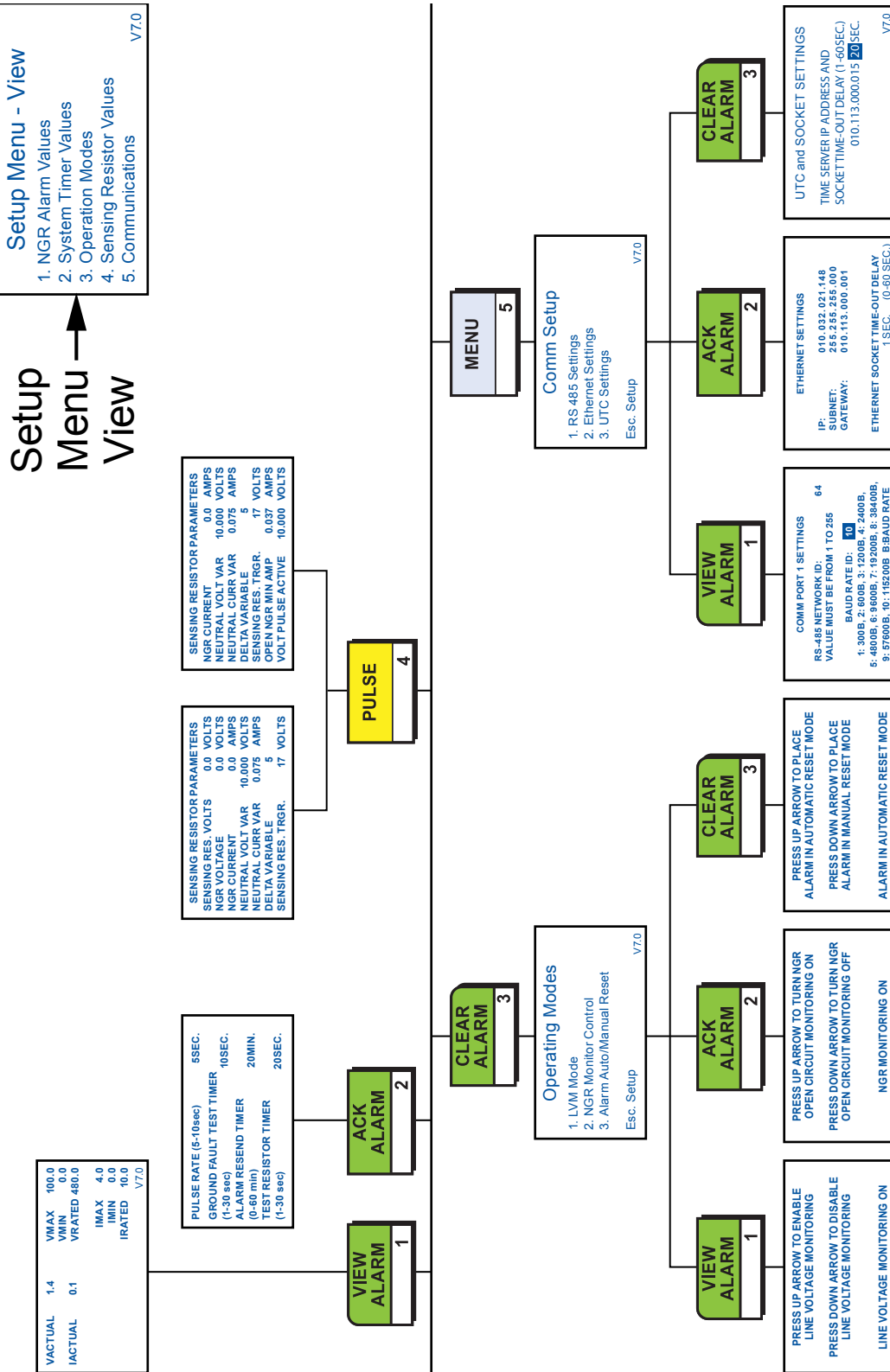

8.4 Software Back-up

The software in the PulserPlus.Net controller is pre-loaded at the factory and is ready to run upon installation. In the unlikely event that the software becomes corrupted and the controller operates erratically, the software can be reloaded in the field. The NGR is still connected and protecting the power system.

Software updates may also be issued by Post Glover Resistors to provide feature enhancements. The procedure below can also be used for those upgrades.

The controller is equipped with a micro-SD card reader. The reader is designed to accommodate up to 2GB micro-SD cards. The controller is delivered with a micro-SD card in the reader. This micro-SD card contains an image of the controller software package. New versions of the software can be copied from the user's PC to the SYSTEM directory of the card. This image cannot be opened and viewed on the customer PC.

To re-load or upgrade the software image, follow the steps below:

1. Press and hold the “**SYSTEM INFO**” front panel button until the “**Enter Password**” screen appears. Input “**1111**” as the password and press the “**Enter**” key.

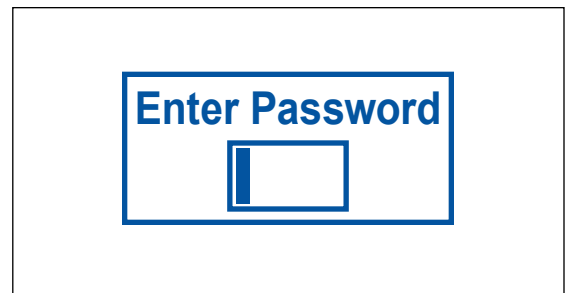
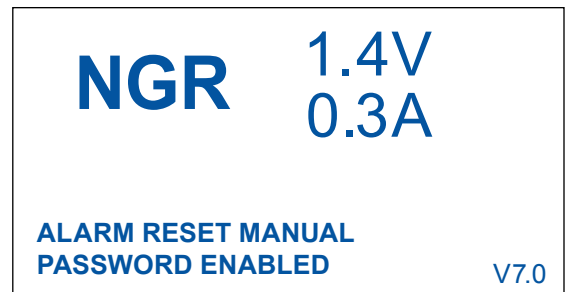

2. On the “**Info Main Menu**” screen, press the “**2**” key for the “**System**” menu.

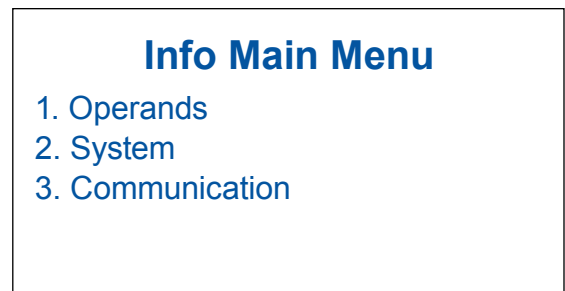

PULSERPLUS.NET™ INSTRUCTION MANUAL

3. On the “**System**” screen, press the “**7**” key for the “**SD**” menu.

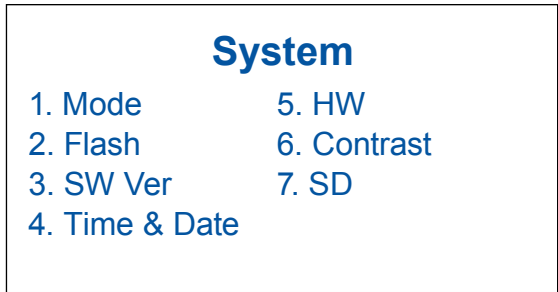

4. On the “**SD**” screen, press the “**1**” key for the “**Restore from SD**” menu. The other menu selection is password protected and is not accessible to the customer.



5. On the “**Restore from SD**” menu, press the “**5**” key for cloning.

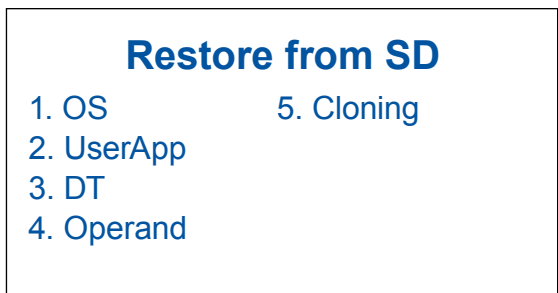

6. Select the appropriate file using the arrow keys and press enter. Press enter again at the confirmation. This loads the software image stored on the SD card.

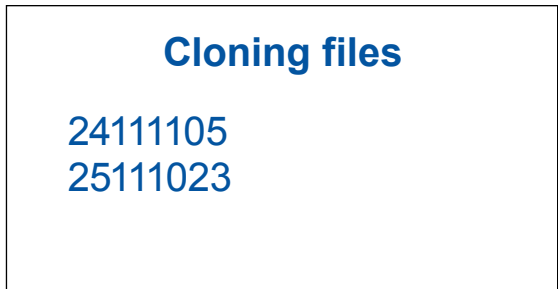

7. Upon completion of the reloading process, the controller will reboot and be ready for operation. System data previously entered by the customer will need to be re-entered.

Section 9 – Maintenance

Normally, no maintenance is necessary for the PulserPlus.Net high resistance grounding system. However, periodic inspections are needed to ensure that the controller is functioning correctly and the resistor is still capable of protecting the system. Post Glover Resistors recommends that the periodic inspections coincide with your normal system Preventative Maintenance schedule.

The following procedure is recommended for periodic field inspections:

1. De-energize the system being grounded. Open the disconnect switch on the PulserPlus.Net, which will de-energize the control circuits and isolate the connection between the system neutral and ground. Always use proper lock-out/tag-out procedures when working on electrical equipment.
2. Open the front door of the control enclosure. For systems with a separately mounted resistor, remove the front and rear covers of the resistor enclosure. This will allow for a visual inspection of all internal components.
3. Check the enclosure for signs of damage from weather or rodents. Remove any dirt or debris from the inside of the enclosure using a vacuum cleaner.
4. Carefully check for cracked insulators and resistor cores. A MEGGER or Hi-Pot test is the most reliable method of ensuring that the insulation is still providing the necessary electrical isolation. Remove any connections from the resistor elements to ground and the controller before performing one of these tests.
5. Check the resistive element for continuity. Ohmmeter readings made between each neutral tap and the ground side of the resistor should be within 10% of the values on the resistor drawing. If the resistances of the elements are more than 15% different from the drawing values, connections should be checked or the resistors should be replaced. Any open resistors should be replaced.
6. Check all internal connections for tightness. Check wiring for signs of damage from heat or overloads.
7. Replace all side covers removed during inspection and check the mounting bolts for tightness. Close the front door of the control enclosure.
8. After re-energizing the system, perform the Test procedure in [Section 4.6](#) to verify system operation.
9. FOR REPLACEMENT PARTS OR ASSISTANCE, CALL 1-800-537-6144 (or from outside the USA, +1-859-283-0778) or e-mail sales@postglover.com. Please have the resistor nameplate information readily available when you call.

Appendix A – Schematics

The schematics in this section are general schematics.
Refer to the wiring diagrams for the resistor for detailed connections.

A.1 Low-Voltage Wye-Connected

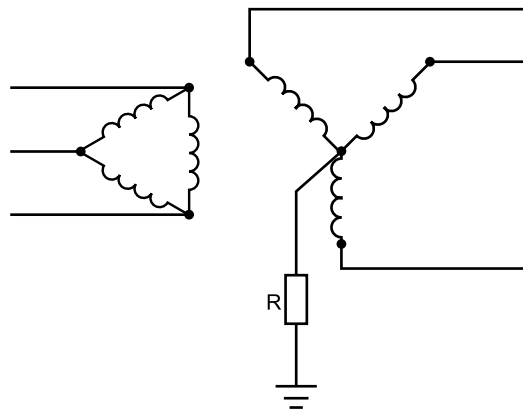

A.2 Low-Voltage Delta-Connected

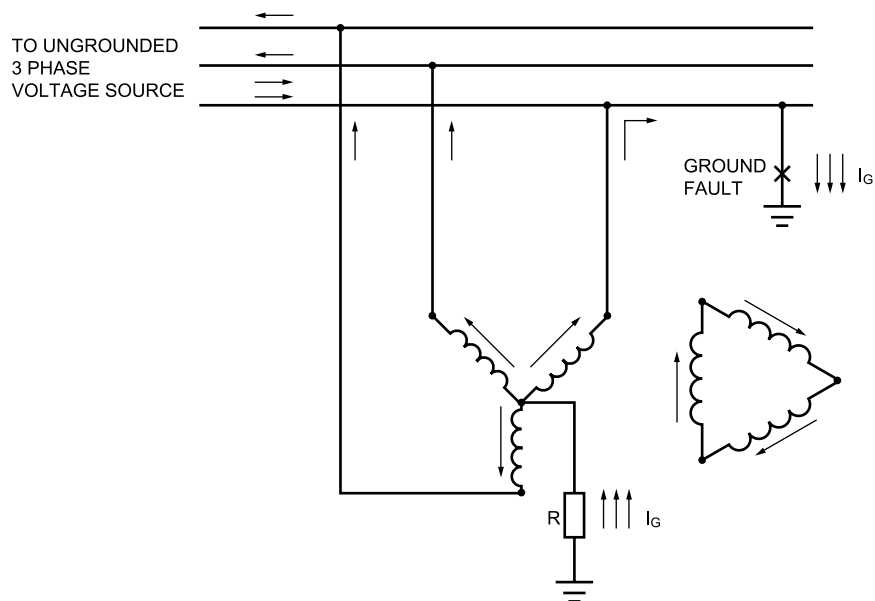

PULSERPLUS.NET™ INSTRUCTION MANUAL

A.3 Trouble shooting schematic

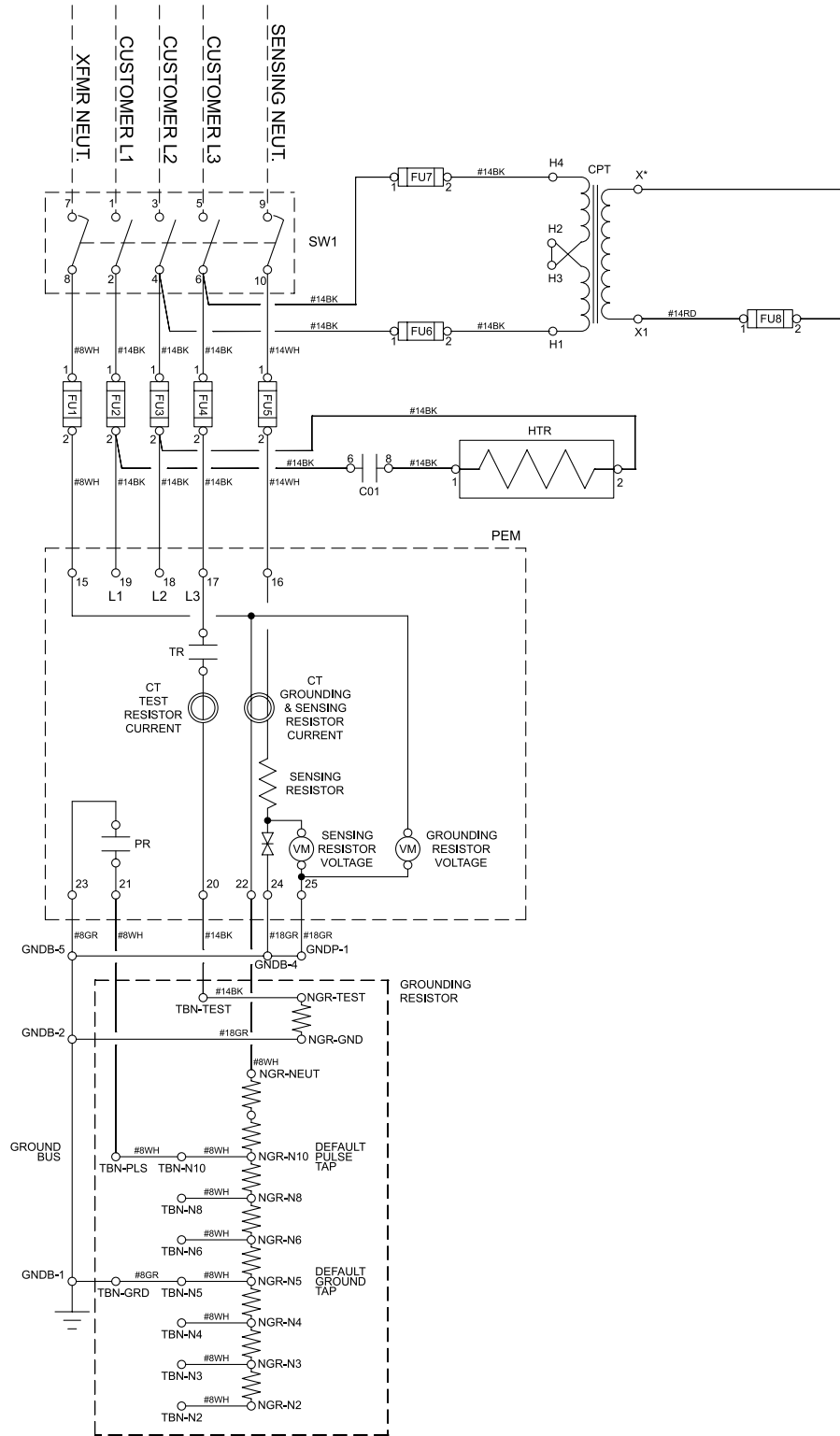

PULSERPLUS.NET™ INSTRUCTION MANUAL

A.3 Trouble shooting schematic (continued)

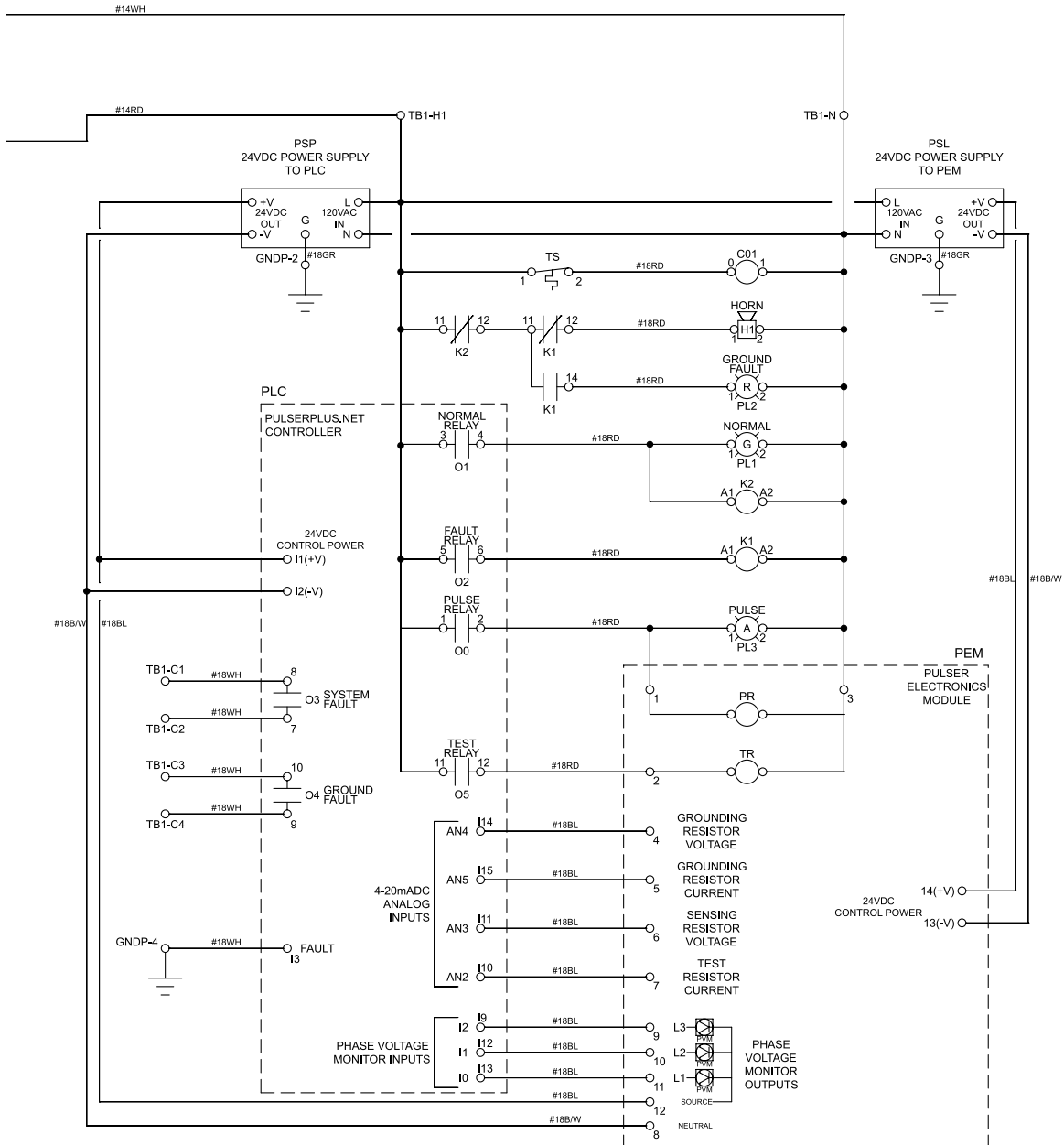

Appendix B – Dimension Drawings

B.1 Low-Voltage Enclosure

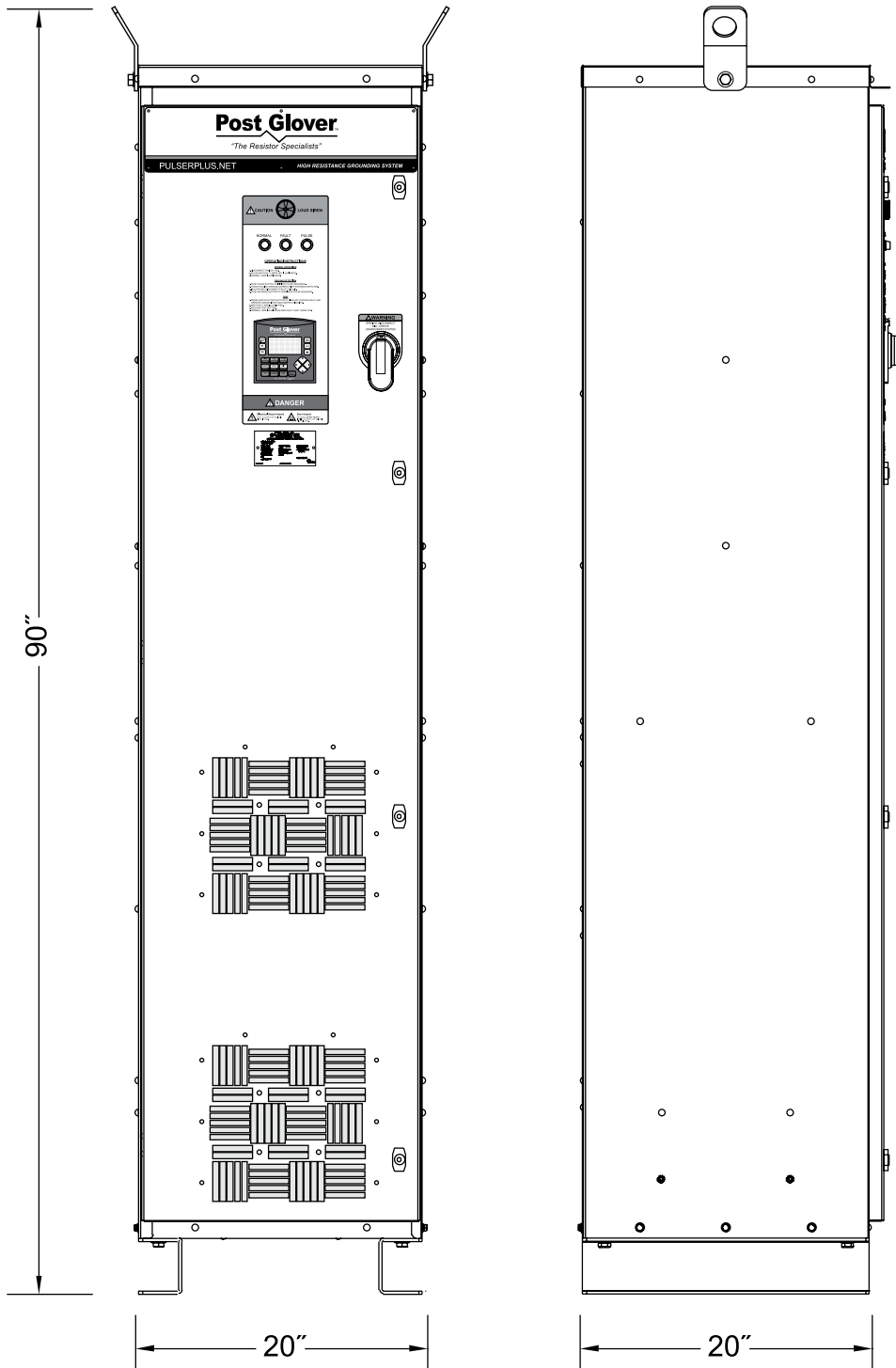

PULSERPLUS.NET™ INSTRUCTION MANUAL

B.2 Low-Voltage Backplate – Heater Model

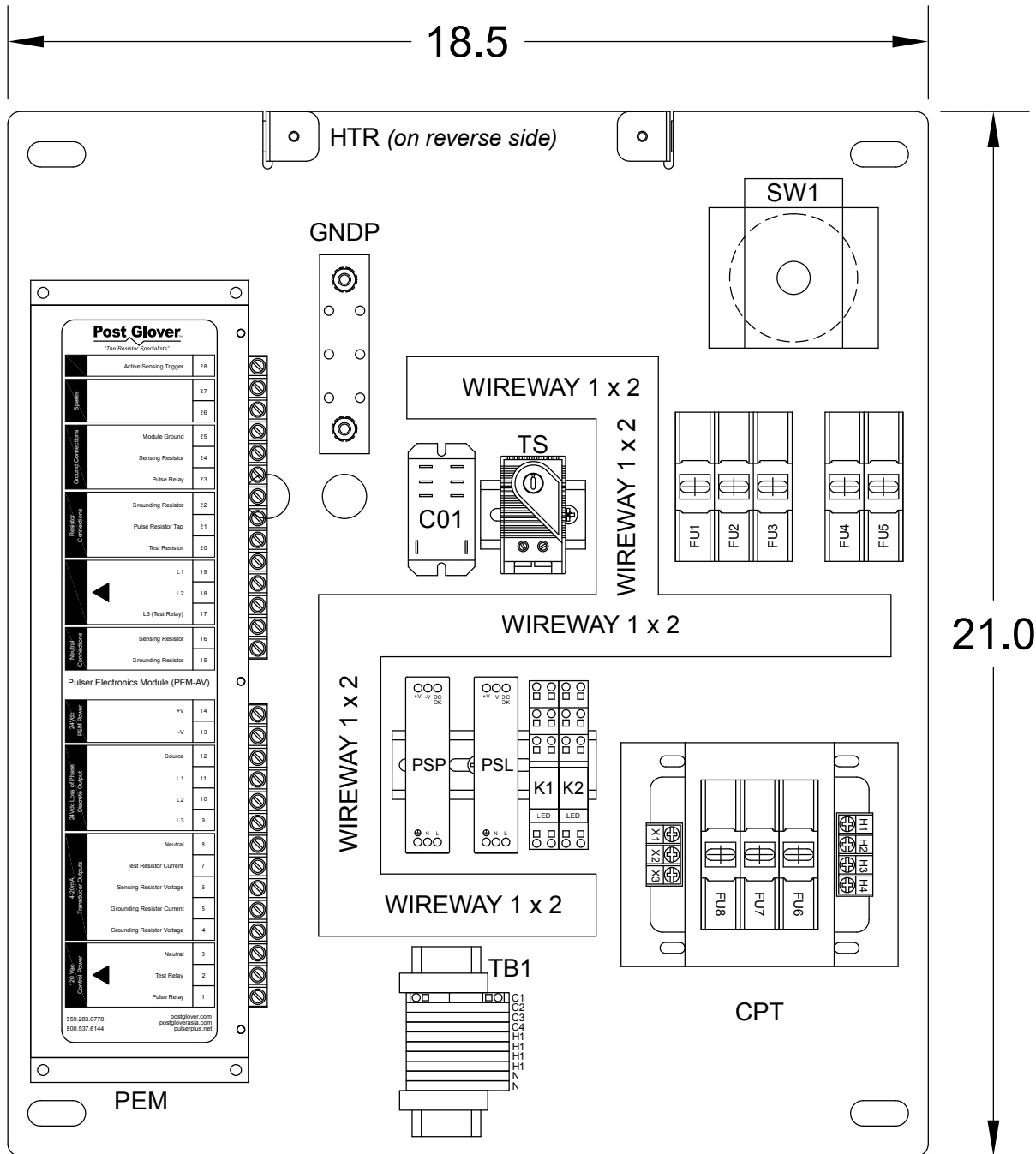

Models without Heater excludes C01 and TS

Appendix C – Control Specifications

C.1 Supply:

1. Controller: 24VDC, 165mA; 20.4VDC to 28.8VDC with less than 10% ripple
2. Pulser Electronics Module: 24VDC

C.2 Ground Circuits:

1. Pulser Electronics Module (PEM)
 - a) Voltage Limit: 600VAC
 - b) Current Limit: 30A

C.3 Controller Output Relays:

1. System Normal: 5A @ 250VAC 30VDC
2. Ground Fault: 5A @ 250VAC 30VDC
3. Pulser: 5A @ 250VAC
4. Test: 5A @ 250VAC

C.4 Digital Inputs:

1. Nominal input voltage: 24VDC
2. Source type: 0-5VDC for Logic '0', 17-28.8VDC for Logic '1'
3. Input current: 8mA @ 24VDC

C.5 Analog Inputs:

1. 4-20mA, 243 ohm input impedance
2. Resolution: 204 to 1023 (820 units)
3. One configured input updated per scan. All analog inputs updated in 4 scans. Scan time approximately 4 to 5 ms.

C.6 Communication Ports:

1. Port 1: 1 channel, RS-232/RS-485
 - a) Baud Rate: 300 to 115200 bps
 - b) RS-232
 - i) Input voltage: + 20VDC absolute maximum
 - ii) Cable length: 15m/50ft maximum
 - c) RS-485
 - i) Input voltage: -7 to +12VDC differential maximum
 - ii) Cable type: Shielded twisted pair
 - iii) Cable length: 1200m/4000ft maximum
 - iv) Nodes: Up to 32
2. Port 2: Ethernet

C.7 SD Card

1. Type of Port: Micro SD
2. Maximum Card size: 32GB

C.8 Miscellaneous

1. Real-time clock (date and time)
2. Battery back-up: 7 years typical at 25°C
3. Battery: Coin-type 3V, lithium battery, CR2450
4. Maximum torque on connection screws, main disconnect switch: 15 in-lb.

PULSERPLUS.NET™ INSTRUCTION MANUAL

Appendix D – Customer Connection Details

D.1 Freestanding Unit

The table below indicates the wiring requirements to connect the PulserPlus.Net to the customer switchgear. For each wire, the ending termination locations at the PulserPlus.Net are given along with the wire type, size, color and termination requirements.

Terminal 1	Termination Type	Terminal 2	Termination Type	Wire Type	Wire Size	Wire Color
SW1-1	0.5" stripped wire	Swgr. L1	By customer	105C	#14	Black*
SW1-3	0.5" stripped wire	Swgr. L2	By customer	105C	#14	Black*
SW1-5	0.5" stripped wire	Swgr. L3	By customer	105C	#14	Black*
SW1-7	0.625" stripped wire	Xfmr. X ₀	By customer	90C	#8	White
SW1-9	0.5" stripped wire	Xfmr. X ₀	By customer	90C	#14	White
GNDB	AMP 324043	Ground	By customer	90C	#8	Green

*The three-phase wire color can be the customer's standard colors, such as Brown, Orange, Yellow, etc.

D.2 Wall-Mounted Unit

In addition to the connections above, the wall-mounted unit requires connections between the wall-mounted control unit and the freestanding resistor unit. These additional connections are in the following table:

Terminal 1	Termination Type	Terminal 2	Termination Type	Wire Type	Wire Size	Wire Color
PEM-20	Burndy YAV14	TBN-TEST	T&B 14RB10X	105C	#14	Black
PEM-21	Panduit LCA8-6-L	TBN-PLS	Panduit LCA8-10-L	90C	#8	White
PEM-22	Panduit LCA8-6-L	NGR-NEUT	AMP 324043	90C	#8	White
PEM-23	Panduit LCA8-6-L	GNDB	AMP 324043	90C	#8	Green
PEM-24	Burndy YAV14	GNDB	T&B 14RB10X	105C	#18	Green
GNDP	T&B 14RB10X	GNDB	T&B 14RB10X	105C	#18	Green

If separate open-frame resistors are used instead of separate enclosed resistors, the GNDB connection above is not made and the following connections are made:

Terminal 1	Termination Type	Terminal 2	Termination Type	Wire Type	Wire Size	Wire Color
NGR-TG	T&B 14RB10X	Ground		105C	#14	Green
TBN-GRD	Panduit LCA8-10-L	Ground		90C	#8	Green

PULSERPLUS.NET™ INSTRUCTION MANUAL

Appendix E – Setup Report Form

These pages are intended as means of recording the parameters and settings used when commissioning the Post Glover Resistors PulserPlus.Net. This is not a “how-to” guide, nor is it intended as a substitute for reading the manual.

INSTALLATION INFORMATION			
Unit ID.: _____	Date: _____		
Customer: _____	Serial No.: _____		
System Voltage: _____	NGR Tap: N _____ (Amps)		
Part Number: _____	Pulsing Tap: N _____ (Amps)		
Maximum Time On: _____	PLC Serial No.: _____		
Continuous	Temp Rise.: _____		

ROUTINE INSPECTION	
ENCLOSURE FINISH FREE OF DEBRIS?	Y / N
PHYSICAL INSTALLATION CORRECT?	Y / N
NEUTRAL AND GROUND TERMINATIONS PROPERLY CONNECTED?	Y / N
INTERNAL INSPECTION COMPLETED?	Y / N
CONTROL POWER CORRECTLY CONNECTED (CUSTOMER SOURCE OR CPT)?	Y / N
FIRMWARE VERSION INSTALLED:	V
TIME AND DATE SET?	Y / N
CONTROL CIRCUIT OPERATIONAL TEST SUCCESSFUL?	Y / N
PARAMETERS SET AND EXPLAINED TO CUSTOMER?	Y / N
GROUND FAULT AND PULSING TAP SET TO CUSTOMER SPEC?	Y / N
GROUND FAULT AND PULSING TAP SET BASED ON TEST?	Y / N

NOTES



1369 Cox Avenue • Erlanger, KY 41018 • USA
 Phone: 800-537-6144 / 859-283-0778 • Fax: 859-283-2978
www.postglover.com

Serving the Electrical Industry Since 1892

PULSERPLUS.NET™ INSTRUCTION MANUAL

PARAMETER SETTINGS					
Setup Menu	Parameter	Default	Range	Setting	Section
NGR Alarm Values	VMAX	100 V	0 - 999		4.5.1.1
	VMIN	0 V	0 - 999		4.5.1.2
	VRATED	480 V	0 - 999		4.5.1.3
	IMAX	4 A	0 - 50.9		4.5.1.4
	IMIN	0 A	0 - 50.9		4.5.1.5
	IRATED	10 A	0 - 50.9		4.5.1.6
System Timer Values	PULSERATE	2 SEC	2 - 10		4.5.2.1
	GROUND FAULT TEST TIMER	20 SEC	1 - 30		4.5.2.2
	ALARM RESEND TIMER	20 MIN	0 - 60		4.5.2.3
	TEST RESISTOR TIMER	20 SEC	1 - 30		4.5.2.4
Operation Mode	LINE VOLTAGE MONITORING	ENABLED	EN/DIS		4.5.3.1
	NGR MONITOR CONTROL	ENABLED	EN/DIS		4.5.3.2
	ALARM AUTO/MANUAL RESET	MANUAL	AU/MN		4.5.3.3
Password Management	Enable/Disable PSW	ENABLED	EN/DIS		4.5.5.1
	CHANGE PASSWORD	1000	0 - 9999		4.5.5.2
	CHANGE TIME	2 HR	0 - 99		4.5.5.3
Sensing Resistor Values	NEUTRAL VOLTAGE VAR.	10 V	0 - 20.999		4.5.4.1
	NEUTRAL CURRENT VAR.	0.036 A	0 - 20.999		4.5.4.2
	DELTA VAR.	5 V	0 - 20		4.5.4.3
	SENSING RES. TRIGGER	17 V	15 - 23		4.5.4.4
	OPEN NGR MIN. AMP.	0.036 A	0 - 20.999		4.5.4.5
	VOLT PULSE ACTIVE	10 V	0 - 20.999		4.5.4.6
Test Functions	Test (Ground Fault)	Functions Correctly		Y / N	4.6.1
	System Charging Current	Measured Value:			4.6.2 & Section 5
	Lamp Test	Functions Correctly		Y / N	4.6.3
Communications	RS 485 SETTINGS		ID 1 - 255 BR 1 - 10		COMS. MANUAL
	ETHERNET SETTINGS		0 - 255 SK TO 0 - 60		COMS. MANUAL
	UTC SETTINGS		0 - 255 SK TO 0 - 60		COMS. MANUAL